



Technical data

	Filter class	30 dB(A)	35 dB(A)	Boost
Maximum capacity ^A	ePM ₁₀ 50%	755 m ³ /h	915 m ³ /h	960 m ³ /h
	ePM ₁ 55%	735 m ³ /h	908 m ³ /h	960 m ³ /h
Throw (0.2 m/s) ^B	ePM ₁₀ 50%	5.2 m	7.1 m	7.5 m
	ePM ₁ 55%	5.1 m	7.1 m	7.5 m
Operating range (max. capacity), outside temperature	-20 °C – +40 °C			
Intake filter	ePM ₁₀ 50%, ePM ₁ 55%			
Extract filter	ePM ₁₀ 50%			
Dimensions (Width x Depth x Height)	1150 x 661 x 2260 mm			
Minimum ceiling height	2300 mm			
Weight: standard air handling unit, complete	297 kg			
Color: casing	RAL 9010			
Counterflow heat exchanger	Aluminium			
Air leakage classification cf. EN 1886 (external leakage)	Class L2			
Air leakage classification cf. EN 13141-7, EN 13141-8 (external leakage)	Class A1			
Air leakage classification cf. EN 308 (internal leakage)	Max. 0.5%			
Air leakage classification, main damper, cf. EN 1751	Class 3			
IP code	10			
Duct connection	Ø315 mm			
Free area, inlet opening / free area, extract opening	0.07 m ² / 0.143 m ²			
Condensate pump: capacity / head at 5 l/h	10 l/h / 6 m			
Condensate drain hose: internal diameter / external diameter	Ø6 mm / Ø9 mm			
Supply voltage ^C	220-240V/50Hz, ~1N+PE or 220-240V/50Hz, ~3N+PE			
Maximum power	354 W			
Maximum current	2.76 A			
Power factor	0.56			
Leakage current AC / DC	≤6mA			
Maximum fuse ^C	16 A, 1 phase, type B or 16 A, 3 phase, type B			
Recommended residual current circuit breaker (RCCB)	Type F / Type B			

^A All measurements were performed in a normal operating mode in a standard installation in a test room, dimensioned 8.0 m x 10.0 m x 2.5 m with room attenuation of 8 dB(A).

^B The throw is measured with a 2-3°C subcooled intake air in a test room, dimensioned 8.0 m x 10.0 m x 2.5 m. Measured with extract filter ePM₁₀ 50%.

^C A 3-phase connection must be used if the electric preheating surface is chosen.

Electrical heating surfaces

	Preheating surface	Comfort heating surface
Heat output	2300 W	1700 W
Nominal current	10.00 A @ 230 V	7.39 A @ 230 V
Thermal circuit breaker, automatic reset	50 °C	50 °C
Thermal circuit breaker, manual reset	100 °C	100 °C

Capacity with intake filter ePM₁₀ 50% + extract filter ePM₁₀ 50%^D

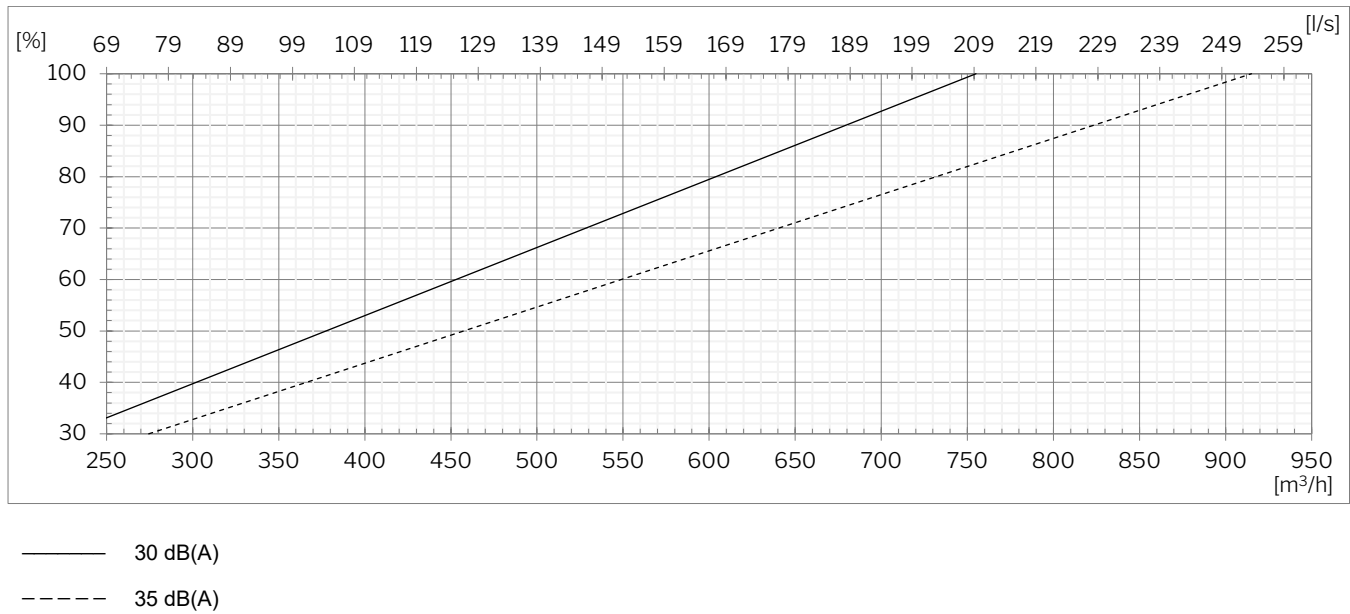

Capacity with intake filter ePM₁ 55% + extract filter ePM₁₀ 50%^D

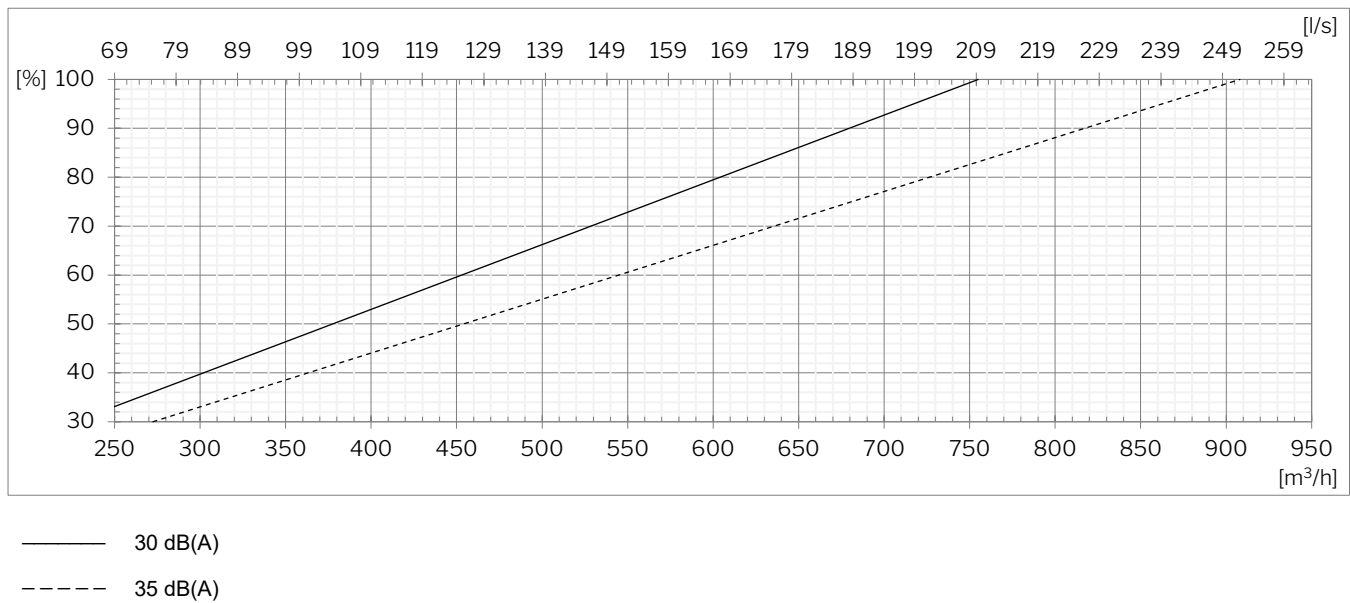

^D All measurements were performed in normal operating mode in a standard installation using the Ø315 mm Airmaster Boomerain® façade grilles.

A-weighted sound pressure level L_{pA} acc. to Airmaster reference situation^E

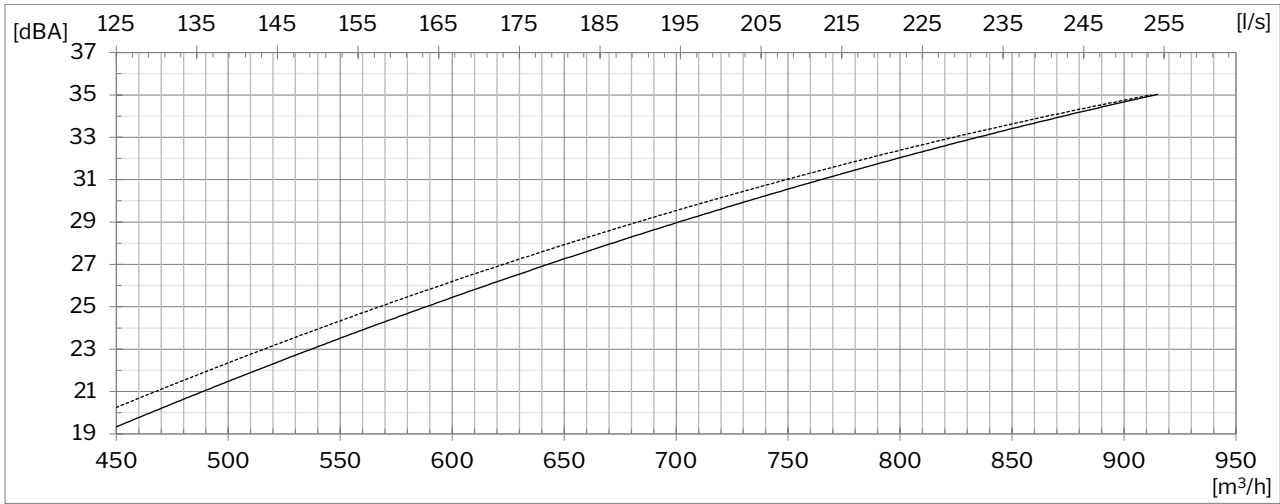

- Intake filter ePM₁₀ 50% + extract filter ePM₁₀ 50%
- Intake filter ePM₁ 55% + extract filter ePM₁₀ 50%

Low-frequency sound:

The sound pressure level measured with C-weighting does not exceed levels measured with A-weighting by more than 20 dB.

Temperature efficiency acc. to EN 308

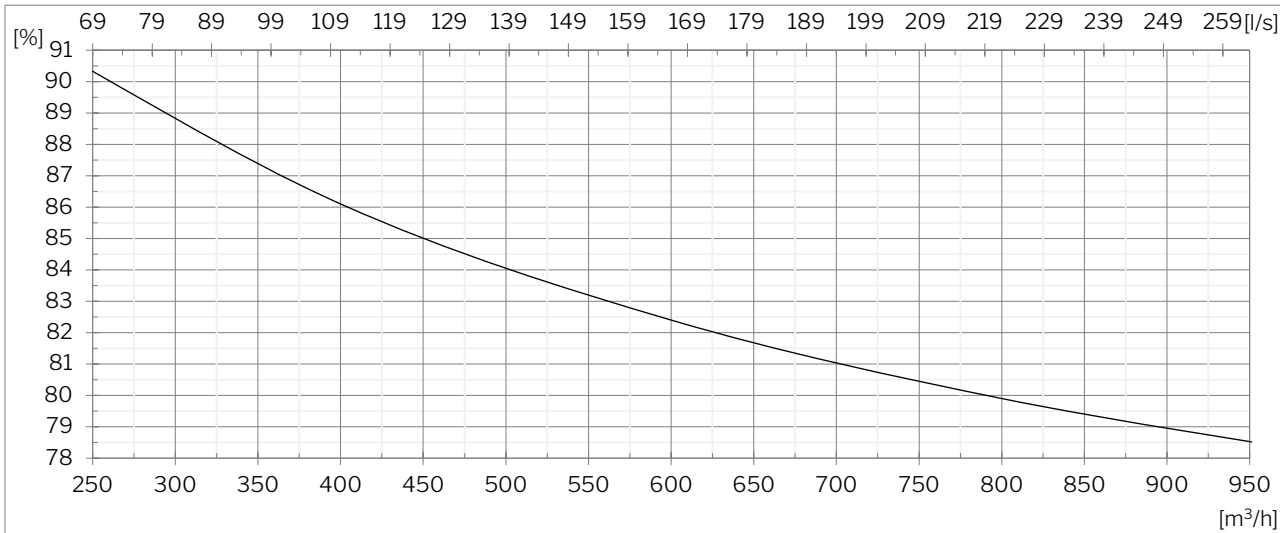

^E The sound pressure level is measured at a height of 1.2 m at a horizontal distance of 1 m from the air handling unit.

Power consumption

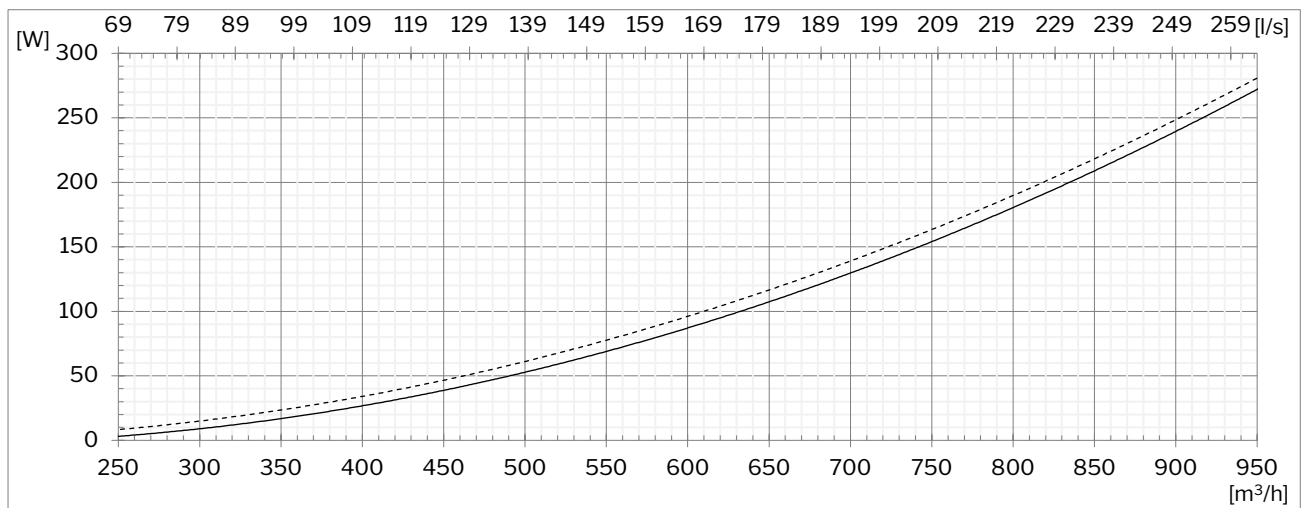

- Intake filter ePM₁₀ 50% + extract filter ePM₁₀ 50%
- - - - Intake filter ePM₁ 55% + extract filter ePM₁₀ 50%

SFP^F

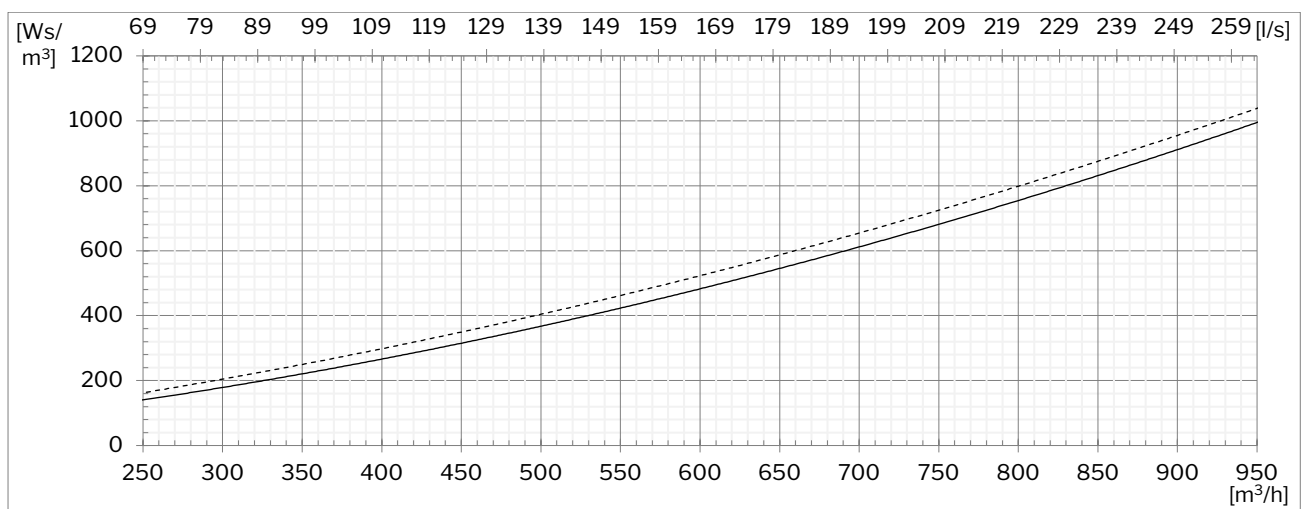

- Intake filter ePM₁₀ 50% + extract filter ePM₁₀ 50%
- - - - Intake filter ePM₁ 55% + extract filter ePM₁₀ 50%

^F The SFP calculation includes power consumption for operating fans but not controls, display panels, etc.

External pressure loss with intake filter ePM₁₀ 50%^G

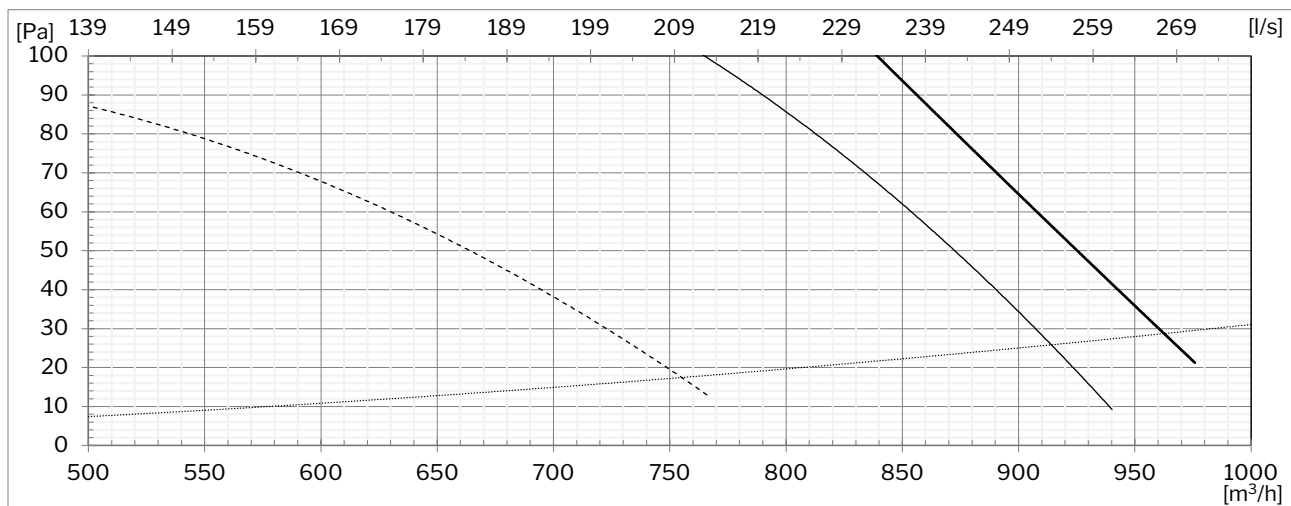

- 30 dB(A)
- 35 dB(A)
- Boost
- Ø315 Boomerain®

External pressure loss with intake filter ePM₁ 55%^G

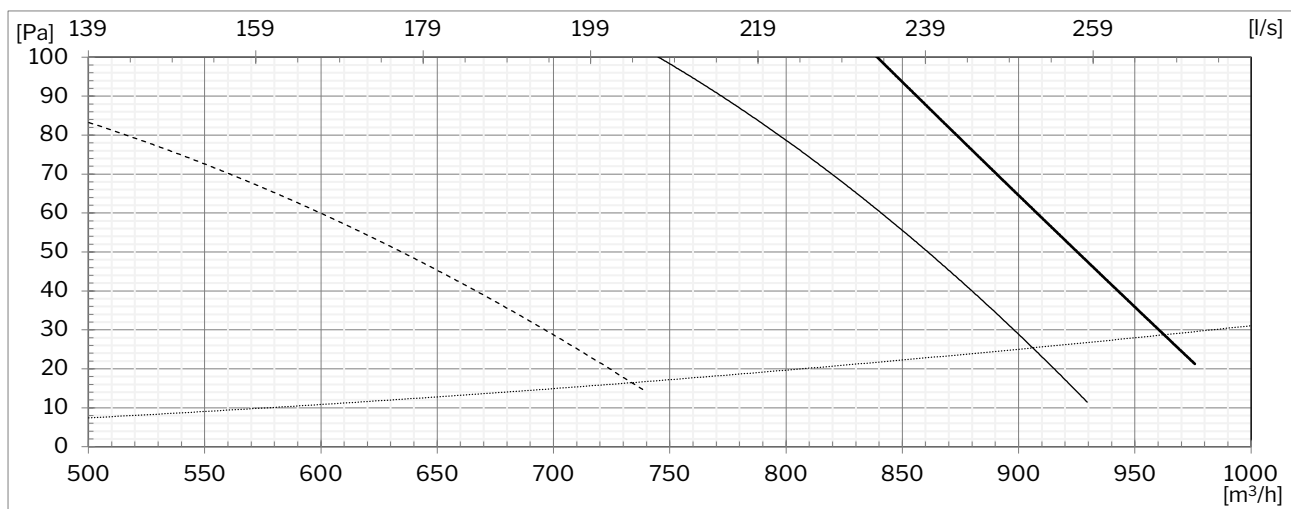

- 30 dB(A)
- 35 dB(A)
- Boost
- Ø315 Boomerain®

^G All measurements were performed in normal operating mode in a standard installation using the Ø315 mm Airmaster Boomerain® façade grilles.



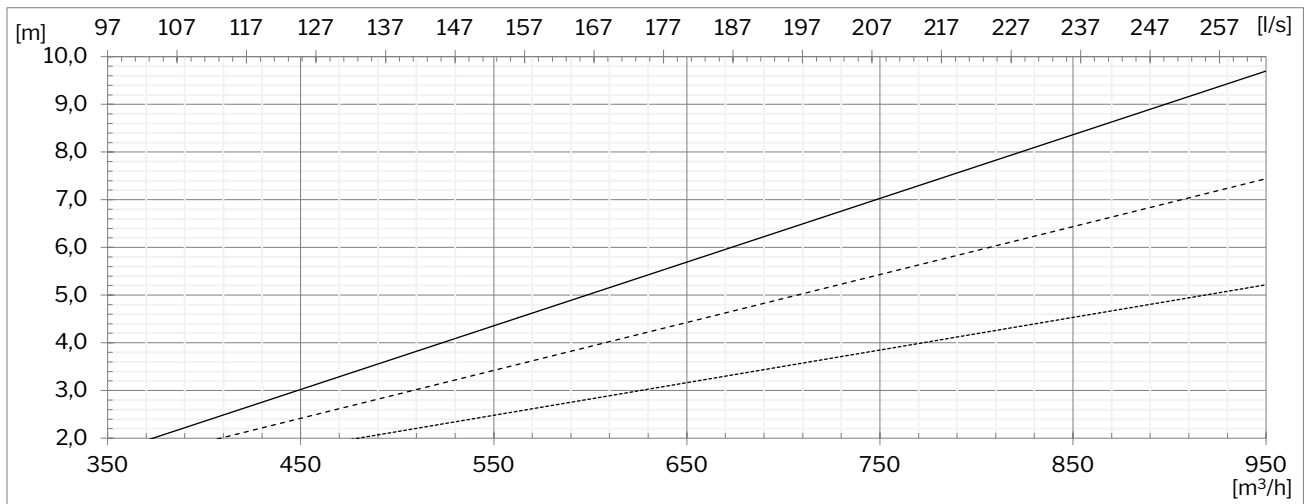

Throw (0.2 m/s)



- Diffuser parallel to flow, 0 deg blade angle @ 0.2 m/s
- - - - - Diffuser small angle away from center, 10 deg @ 0.2 m/s (standard factory setting)
- Diffuser large angle away from center, 30 deg @ 0.2 m/s





Version overview

vv

-  Exhaust
-  Intake
-  Inlet
-  Extract







HH

-  Exhaust
-  Intake
-  Inlet
-  Extract







HH SSL

-  Exhaust
-  Intake
-  Inlet
-  Extract



HH SSR

-  Exhaust
-  Intake
-  Inlet
-  Extract



Standard and options

Counterflow heat exchanger	✓	Intake filter ePM ₁₀ 50%	opt.
Motor-driven bypass	✓	Intake filter ePM ₁ 55%	opt.
Motor-driven intake air damper	✓	Extract filter ePM ₁₀ 50%	✓
Motor-driven exhaust air damper	✓	LED (operating mode indicator)	✓
Electric preheating surface	opt.	Airlinq® Viva control panel	opt.
Electric comfort heating surface	opt.	Airlinq® Orbit control panel	opt.
Condensate pump	opt.	Airmaster Airlinq® Online Stand-alone	opt.
CO ₂ sensor, integrated	opt.	Airmaster Airlinq® Online	opt.
TVOC sensor, integrated	opt.	Airlinq® Online API	opt.
CO ₂ & TVOC sensor, integrated	opt.	Airlinq® BMS	opt.
Motion sensor, wall-mounted	opt.	MODBUS® RTU RS485 module	opt.
Hygrostat, wall-mounted	si	BACnet™ IP module	opt.
Smoke detector, integrated	opt.	BACnet™ MS/TP module	opt.
Energy Meter, single-phase	opt.		
Energy Meter, three-phase	opt.		
Casters with mounting feet	opt.		

✓: standard opt.: optional si: special item

Schematic sketch

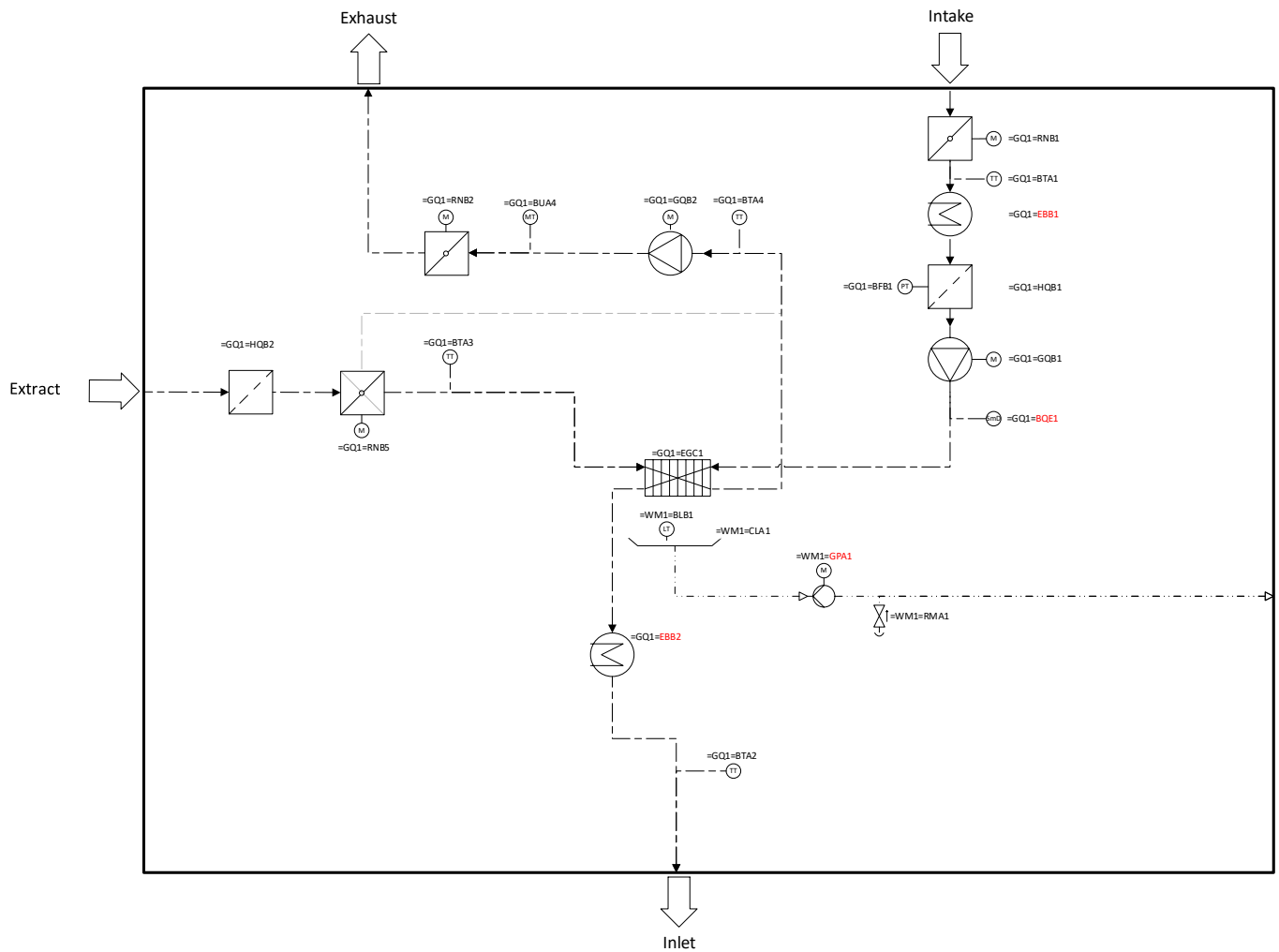

Component designation:

=GQ1 Ventilation system
=WM1 Condensation system

=BFB	Pressure monitor	=CLA	Condensate tray	=GQB	Fan
=BLB	Float switch	=EBB1	Electric preheating surface (option)	=HQB	Filter
=BTA	Temperature sensor	=EBB2	Electric comfort heating surface (option)	=RMA	Air vent with non-return valve
=BUA	CO ₂ sensor	=EGC	Heat exchanger	=RNB	Damper
=BQE1	Smoke detector (option)	=GPA1	Condensate pump (option)		