



Datasheet AM 900

Mixing ventilation

Technical data	Filter class	30 dB(A)	33 dB(A)	35 dB(A)
Maximum capacity ¹	ePM ₁₀ 50%	690 m ³ /h	760 m ³ /h	830 m ³ /h
	ePM ₁ 55%	669 m ³ /h	737 m ³ /h	805 m ³ /h
	ePM ₁ 80%	649 m ³ /h	714 m ³ /h	780 m ³ /h
Throw (0,2 m/s) ²		6 m	-	7.2 m
Supply air filter		ePM ₁₀ 50%, ePM ₁ 55%, or ePM ₁ 80%		
Extract air filter		ePM ₁₀ 50%		
Dimensions (BxHxD)		800 x 2323 x 602 mm		
Recommended minimum ceiling height / minimum ceiling height		2490 mm / 2400 mm ³		
Weight, standard air handling unit, complete		180 kg		
Color casing		RAL 9010		
Counterflow heat exchanger		3 x PET (Polyetylentereftalat)		
Air leakage classification cf. EN1886/EN13141-7		Class L2 / A1		
Air leakage classification main damper, cf. EN1751		Class 3		
IP code		10		
Duct connection		Ø315 mm		
Condensate pump (Capacity ; Lifting height at 5 l/h)		10 l/h ; 6 m		
Condensate drain hose int./ext. diameter		Ø4 mm / Ø6 mm		
Supply voltage		220-240V/50Hz, ~1N+PE		
Nominal power consumption ¹		240 W		
Nominal current ¹		1,8A		
Power factor		0,6		
Maximum fuse		16 A (1 phase, type B)		
Leakage current AC / DC		≤ 6mA		
Recommended residual current breaker (RCCB)		Type B		
Electrical heating surfaces		Preheating surface	Comfort heating surface	
Heat output		1500 W	1050 W	
Nominal current		6.5 A	4.4 A	
Thermal circuit breaker, manual reset		100 °C	100 °C	
Water heating surface				
Nominal heat output ⁴		2345 W		
Connection dimension		1/2" (DN 15)		
Materials pipes/fins		Copper/aluminum		
Opening/closing time motor valve		60 s		
Maximum operating temperature		90 °C		
Maximum operating pressure		5 bar		

¹ All measurements were performed in normal operating mode in a standard installation using the facade grills recommended by Airmaster: Airmaster Boomerain® Ø315.

² Throw was measured with filter class: supply air ePM₁₀ 50% | Extract air ePM₁₀ 50%

³ With horizontal connections (intake and return) and blowing in at the front (door)

⁴ Heat output for maximum capacity at 35 dB(A), delivery/return temperature 60/40°C and a liquid flow of 111 l/h.

Capacity with ePM₁₀ 50% / ePM₁₀ 50% filters ⁵

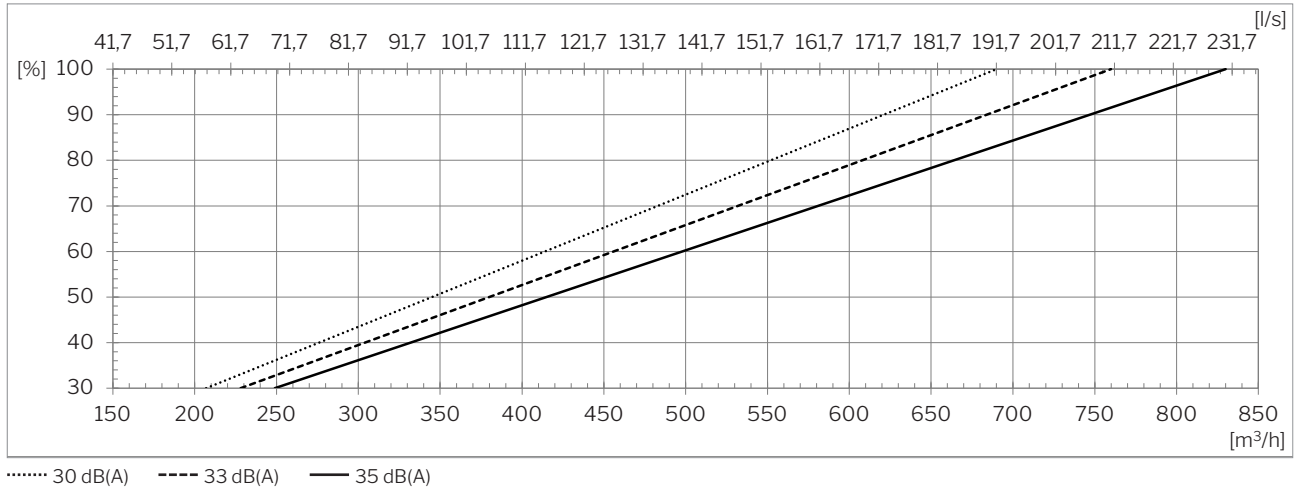

Capacity with ePM₁ 55% / ePM₁₀ 50% filters ⁵

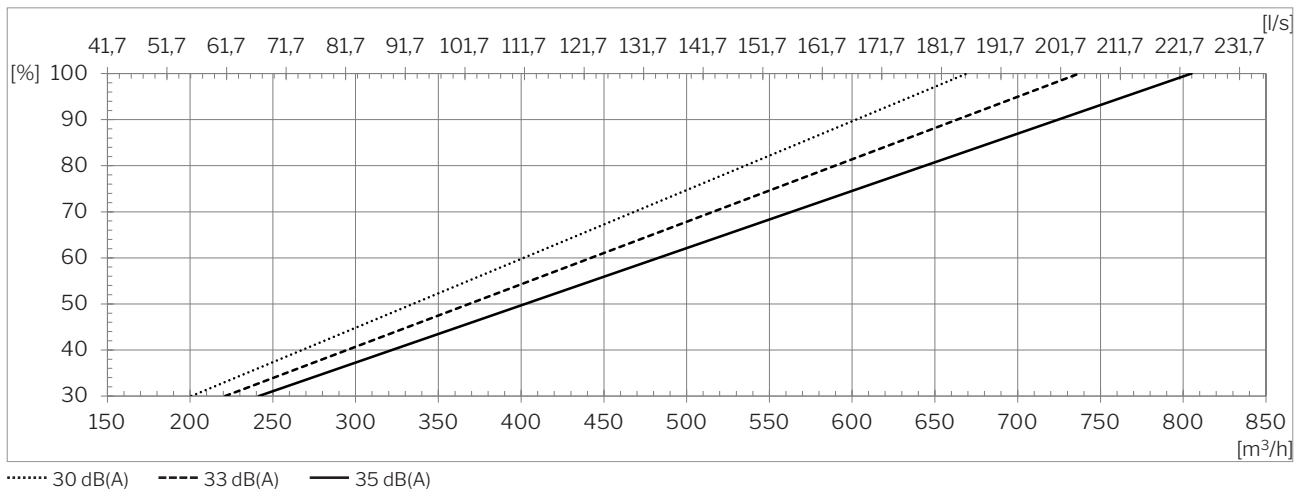

Capacity with ePM₁ 80% / ePM₁₀ 50% filters ⁵

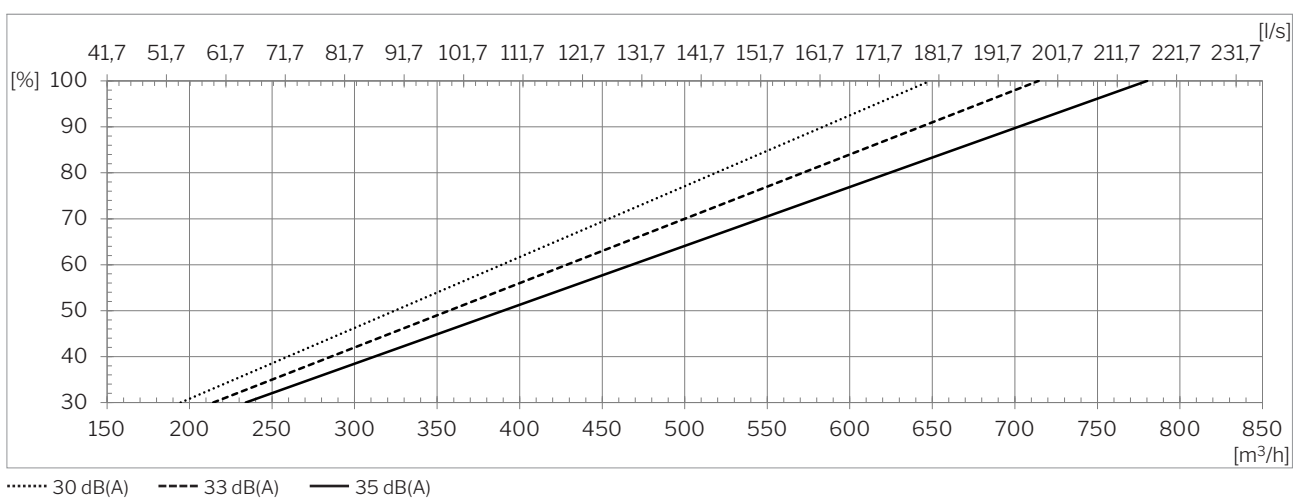

⁵ All measurements were performed in normal operating mode in a standard installation using the facade grills recommended by Airmaster: Airmaster Boomerain® Ø315.

Sound pressure $^{6,7} L_{pA,eq}$ acc. Airmaster reference situation

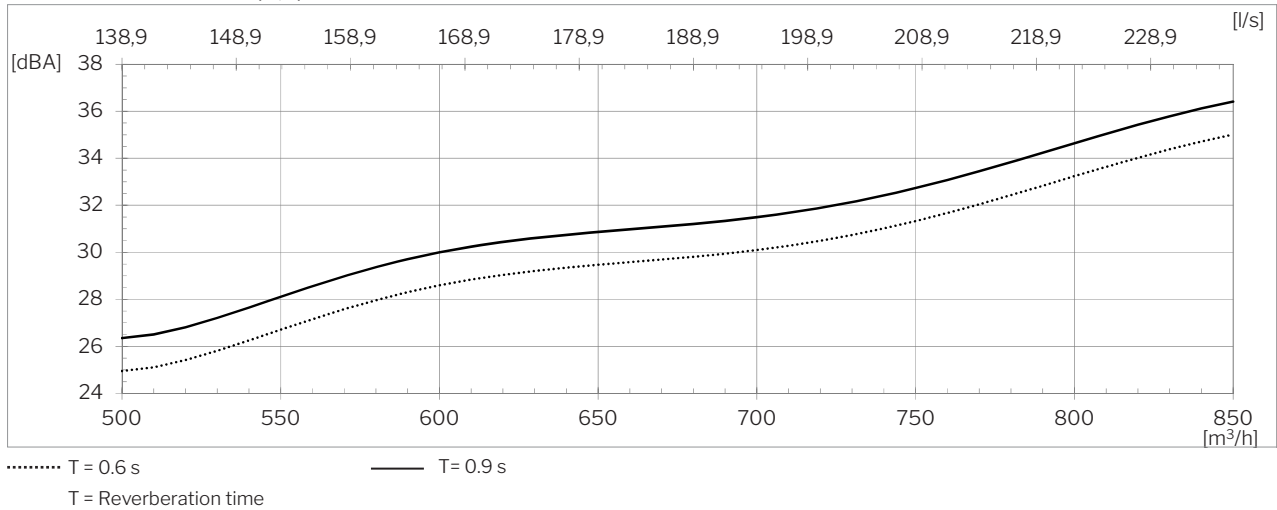

Temperature efficiency acc. EN 308

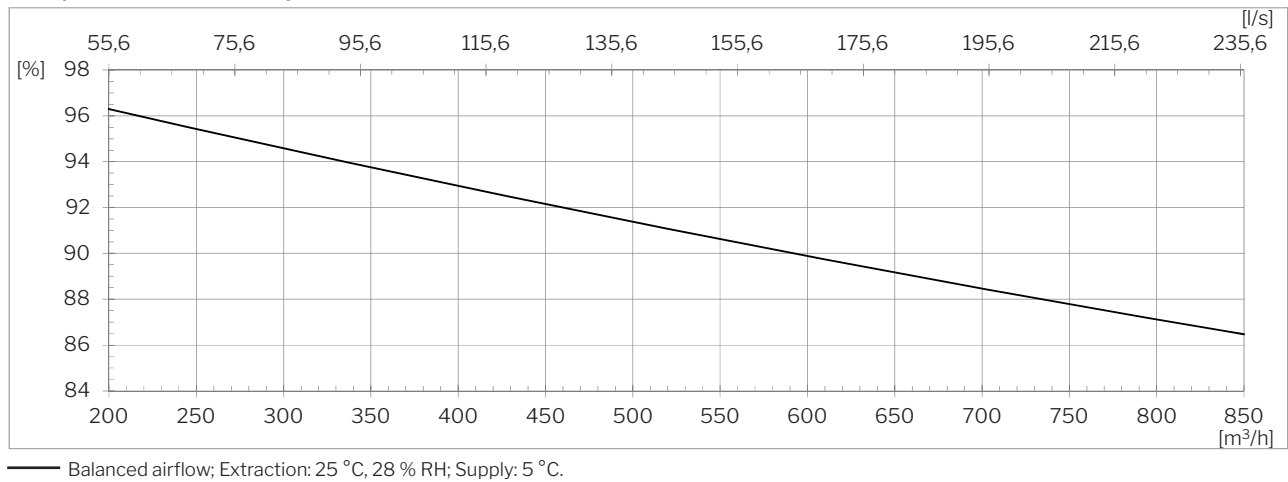

Power consumption ⁷

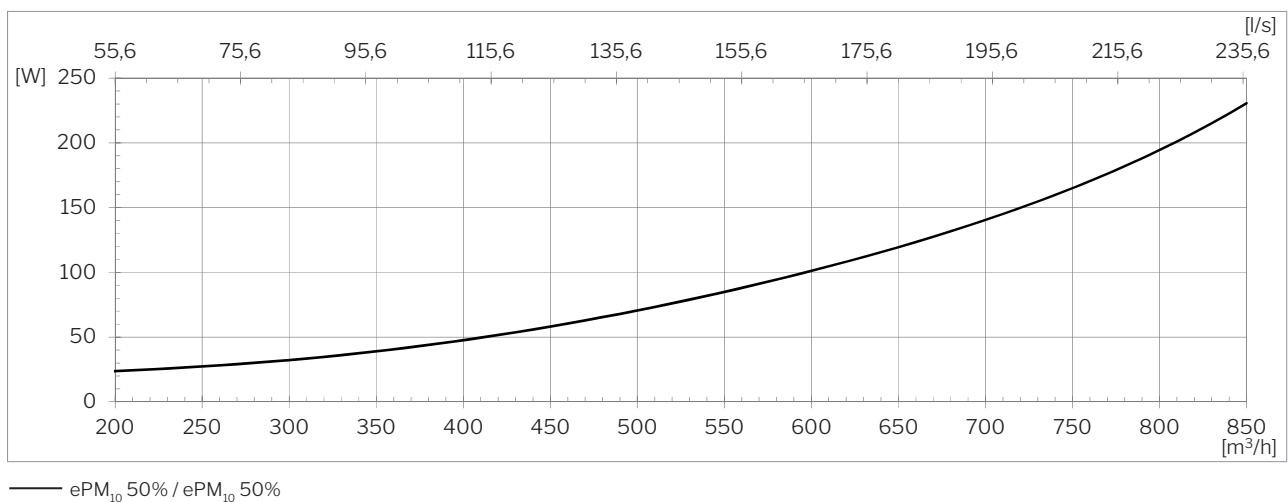

⁶ Sound pressure level $L_{pA,eq}$ is measured in a height of 1.2 m with at horizontal distance of 1 m from the air handling unit in room with a size of 200 m³ and a reverberation time of T = 0.6 s, corresponding to a room attenuation of 7.5 dB.

⁷ All measurements were performed in normal operating mode in a standard installation for the filter class, supply/extract air: ePM10 50% / ePM10 50%, using the facade grills recommended by Airmaster: Airmaster Boomerain® Ø315.

SFP⁸

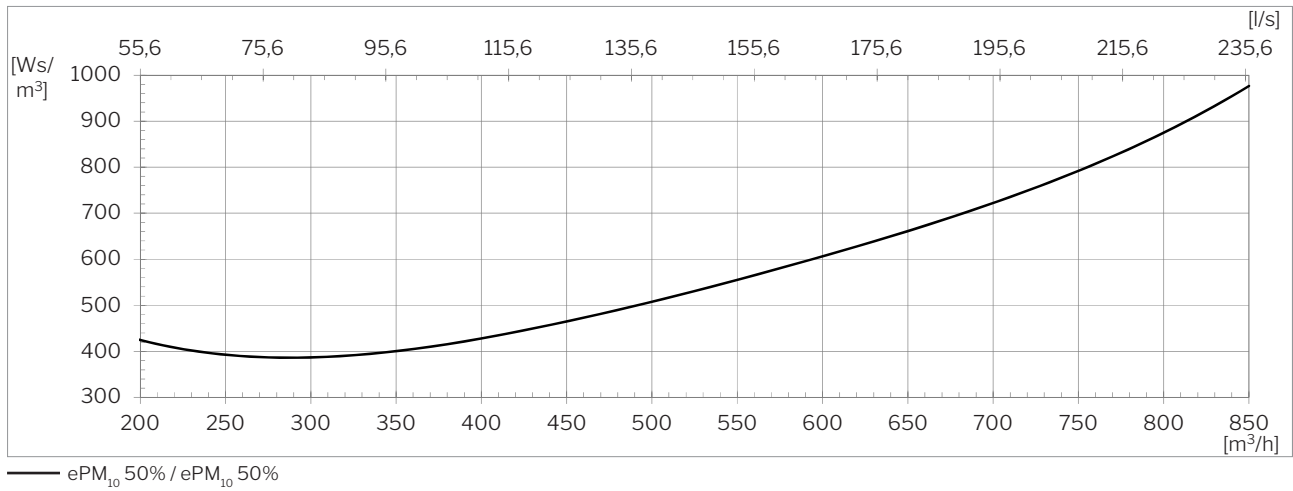

External pressure loss⁸

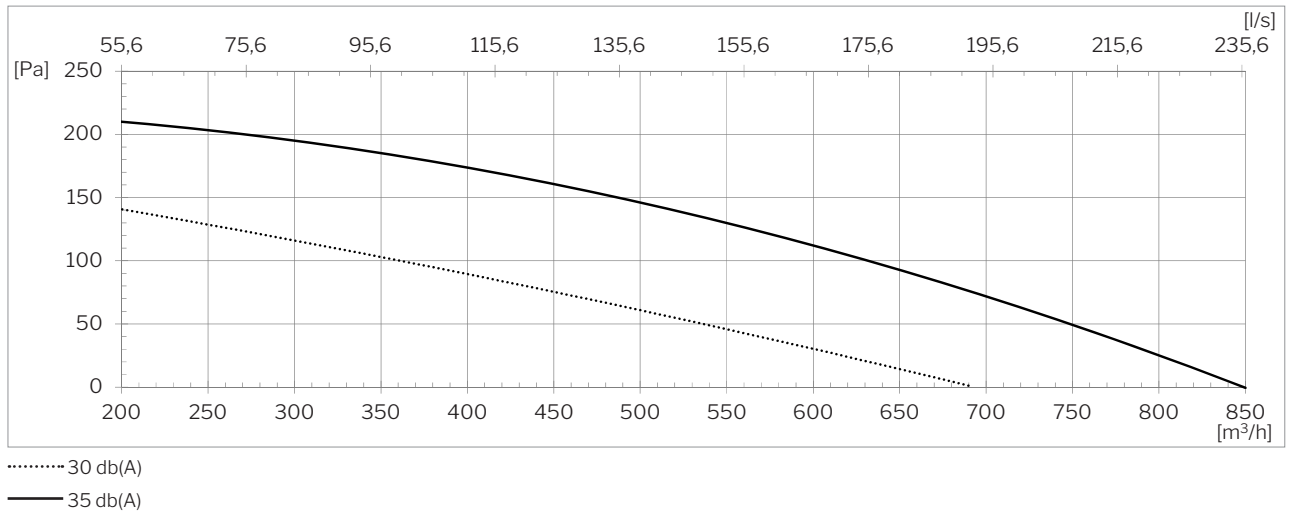

⁸ All measurements were performed in normal operating mode in a standard installation for the filter class, supply/extract air: ePM10 50% / ePM10 50%, using the facade grills recommended by Airmaster: Airmaster Boomerain® Ø315.

Throw⁹ (0.2 m/s)

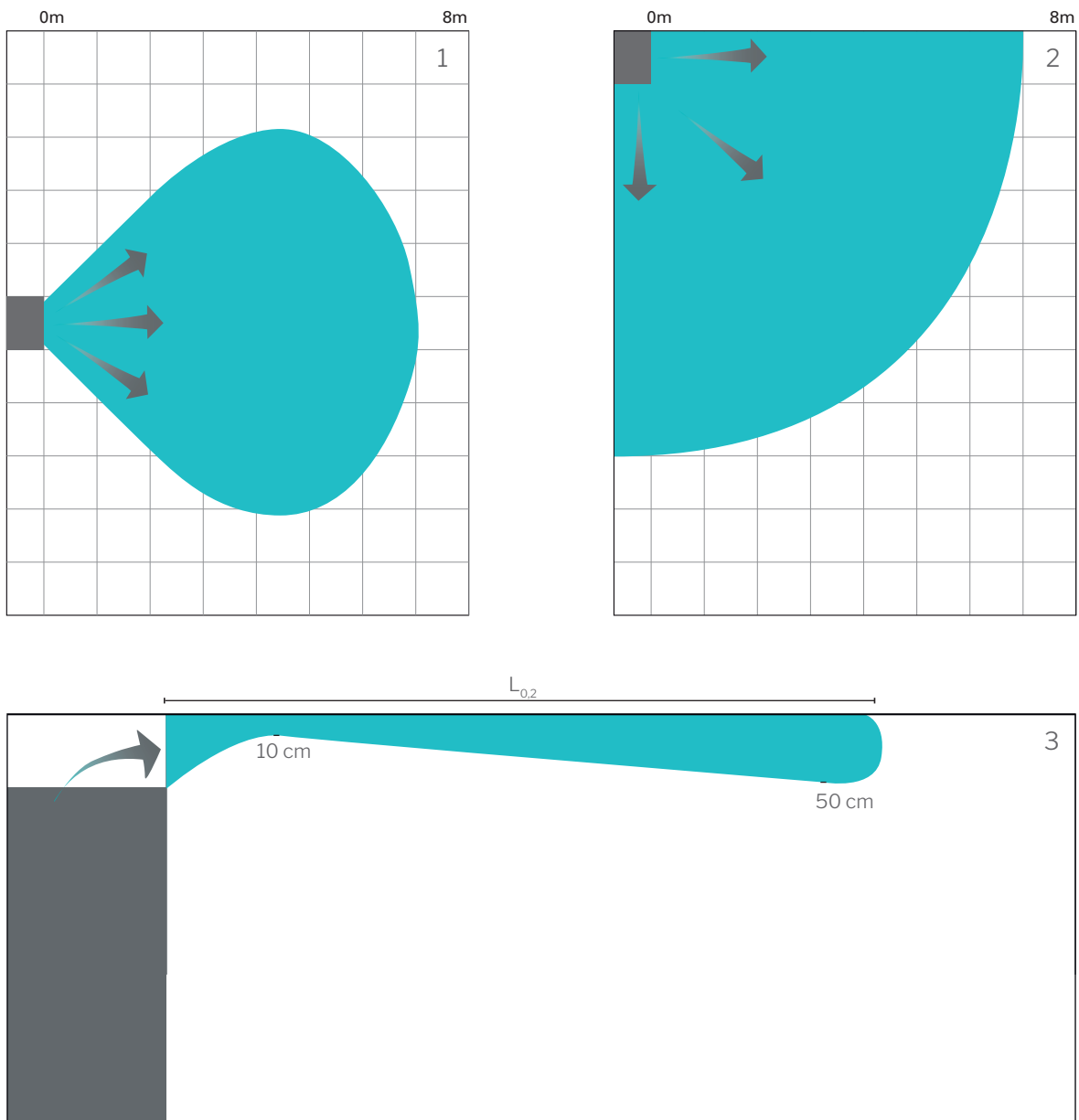

Throw illustrated for airflow rate 830 m³/h. At other volume flow rates the throw can be extrapolated:

$$L_2 = L_1 \times q_2 / q_1$$

- 1 Spread pattern seen from above, symmetric inlet (default).
- 2 Spread pattern seen from above, asymmetric inlet.
- 3 Spread pattern seen from the side.

⁹ The result applies to an undertemperature of the inlet air of 3-5 °C.

Standard and options

Counterflow heat exchanger (PET)	x	Energy meter	•
Enthalpy counterflow heat exchanger (Polymer membrane)	o	Supply air filter ePM ₁₀ 50%	•
Combination counterflow heat exchanger (Polymer membrane)	o	Supply air filter ePM ₁ 55%	•
Motor-driven bypass	x	Supply air filter ePM ₁ 80%	o
Motor-driven supply air damper	x	Extract air filter ePM ₁₀ 50%	x
Motor-driven extract air damper	x	Airlinq® Viva control panel	•
Capacitive return for motorized exhaust and supply air dampers	•	Airlinq® Orbit control panel	•
Electric preheating surface	•	Airmaster Airlinq® Online	•
Electric comfort heating surface	•	Airlinq® Online API	•
Water heating surface	o	Airlinq® BMS	•
Condensate pump	•	LON® module	o
PIR/motion sensor (wall-mounted)	•	KNX® module	o
CO ₂ -sensor (wall-mounted)	•	MODBUS® RTU RS485 module	•
CO ₂ -sensor (built-in)	•	BACnet™ MS/TP module	•
TVOC-sensor (built-in)	•	BACnet™ /IP module	•
CO ₂ -/TVOC-sensor (built-in)	•		
Hygrostat (wall-mounted)	o		

X : Standard • : Optional o : Special item (not stock item)

Schematic sketch

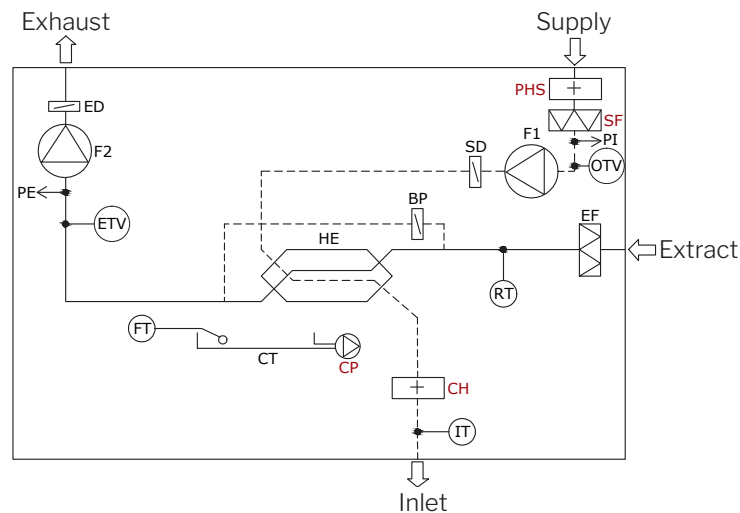

COMPONENT DESIGNATION

BP	Bypass damper (motor-driven)	EF	Extract air filter	OTV	Supply air temperature sensor
CH	Electric comfort heating surface (option)	ETV	Exhaust temperature sensor	PE	Flow meter, extracted air
CP	Condensate pump (option)	FT	Float	PHS	Preheating surface (option)
CT	Condensate tray	F1	Supply air fan	PI	Flow meter, supply air
ED	Exhaust air damper (motor-driven)	F2	Extract air fan	RT	Room temperature sensor
		HE	Counterflow heat exchanger	SD	Supply air damper (Motor-driven)
		IT	Inlet-air temperature sensor	SF	Supply air filter (option)