



Datasheet AM 900

Displacement ventilation

Technical data	Filter class	30 dB(A)	33 dB(A)	35 dB(A)
Maximum capacity ¹	ePM ₁₀ 50%	650 m ³ /h	725 m ³ /h	800 m ³ /h
	ePM ₁ 55%	631 m ³ /h	703 m ³ /h	776 m ³ /h
	ePM ₁ 80%	611 m ³ /h	682 m ³ /h	752 m ³ /h
Adjacent zone (0.2 m/s) ²		approx. 1.2 m at 650 m ³ /h		approx. 1.5 m at 800 m ³ /h
Supply air filter		ePM ₁₀ 50%, ePM ₁ 55% eller ePM ₁ 80%		
Extract air filter		ePM ₁₀ 50%		
Dimensions (BxHxD)		800 x 2323 x 687 mm		
Minimum ceiling height		2490 mm		
Weight, standard air handling unit, complete		180 kg		
Color casing		RAL 9010		
Counterflow heat exchanger		3 x PET (Polyetylentereftalat)		
Air leakage classification cf. EN1886/EN13141-7		Class L2 / A1		
Air leakage classification main damper, cf. EN1751		Class 3		
IP-code		10		
Duct connection		Ø315 mm		
Condensate pump (Capacity ; Lifting height at 5 l/h)		10 l/h ; 6 m		
Condensate drain hose int./ext. diameter		Ø4 mm / Ø6 mm		
Supply voltage		220-240V/50Hz, ~1N+PE		
Nominal power consumption ¹		240 W		
Nominal current ¹		1,8 A		
Power factor		0.6		
Maximum fuse		16 A (1 phase, type B)		
Leakage current AC / DC		≤ 6mA		
Recommended residual current breaker (RCCB)		Type B		
Electrical heating surfaces		Preheating surface	Comfort heating surface	
Heat output		1500 W	1050 W	
Nominal current		6.5 A	4.4 A	
Thermal circuit breaker, manual reset		100 °C	100 °C	
Water heating surface				
Nominal heat output ³		2345 W		
Connection dimension		1/2" (DN 15)		
Materials pipes/fins		Copper/aluminum		
Opening/closing time motor valve		60 s		
Maximum operating temperature		90 °C		
Maximum operating pressure		5 bar		

¹ All measurements were performed in normal operating mode in a standard installation for the filter class, supply/extract air: ePM10 50% / ePM10 50%, using the facade grills recommended by Airmaster: Airmaster Boomerain® Ø315.

² Adjacent zone to outlet was measured with filter class: supply air ePM₁₀ 50% | Extract air ePM₁₀ 50%

³ Heat output for maximum capacity at 35 dB(A), delivery/return temperature 60/40°C and a liquid flow of 111 l/h.

Capacity with ePM₁₀ 50% / ePM₁₀ 50% filters ⁴

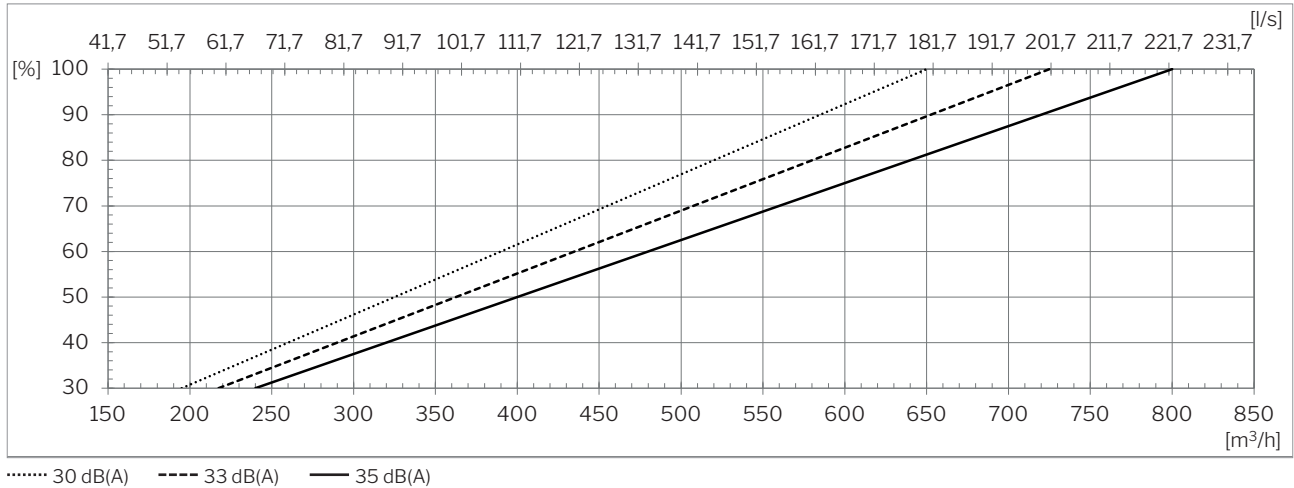

Capacity with ePM₁ 55% / ePM₁₀ 50% filters ⁴

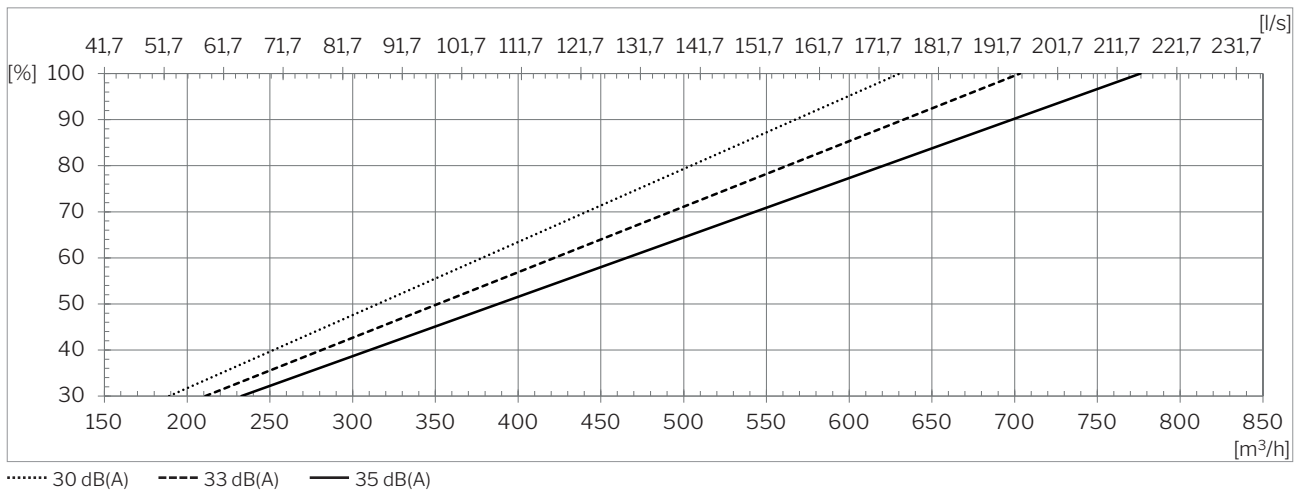

Capacity with ePM₁ 80% / ePM₁₀ 50% filters ⁴

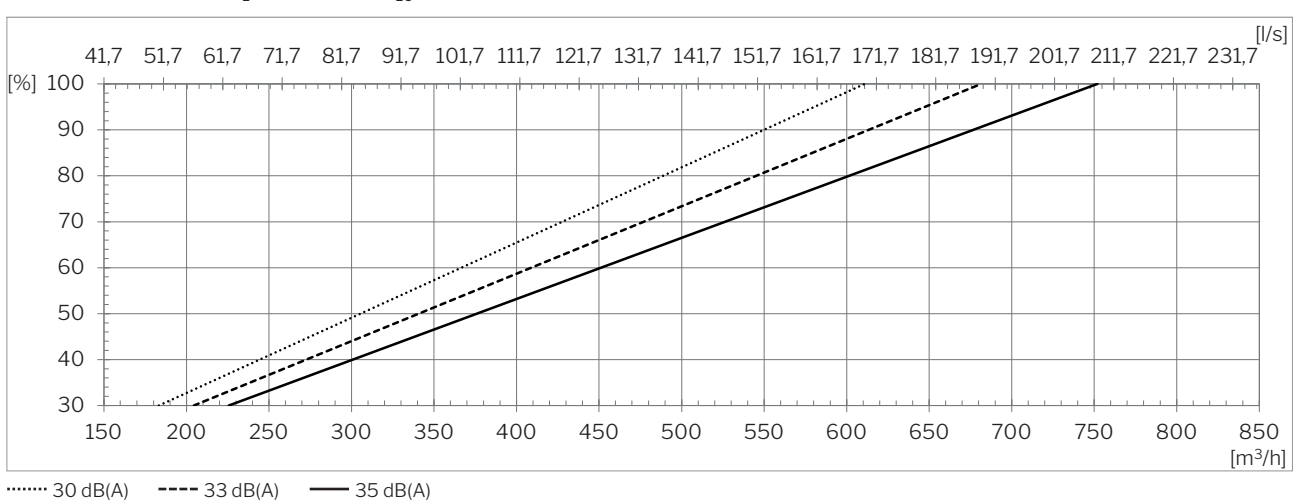

⁴ All measurements were performed in normal operating mode in a standard installation for the filter class, supply/extract air: ePM10 50% / ePM10 50%, using the facade grills recommended by Airmaster: Airmaster Boomerain® Ø315.

Sound pressure ^{5,6} L_{p,eq} acc. Airmaster reference situation

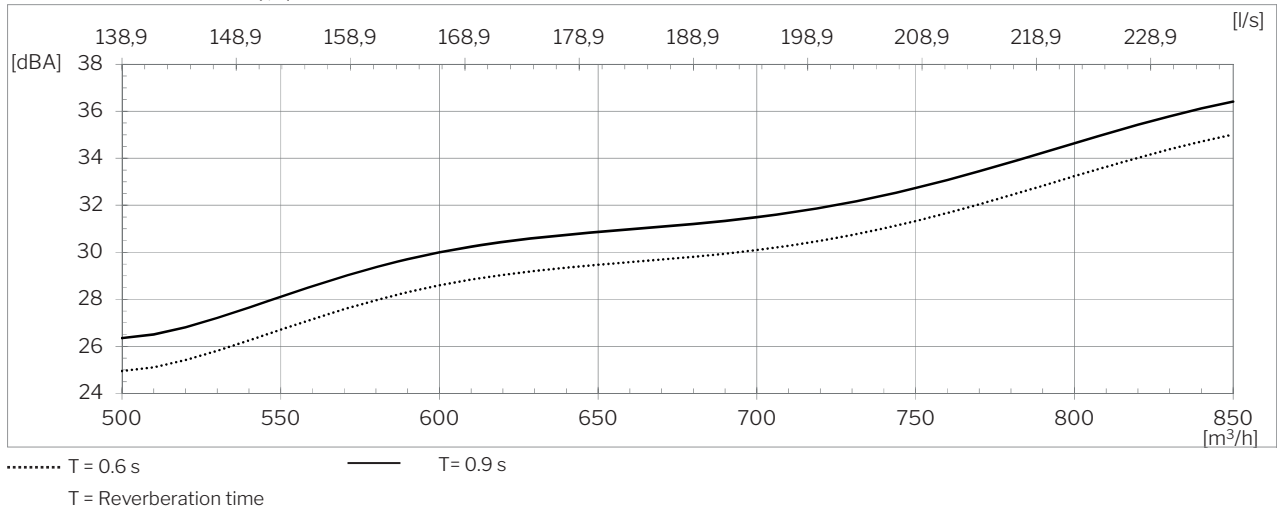

Temperature efficiency acc. EN 308

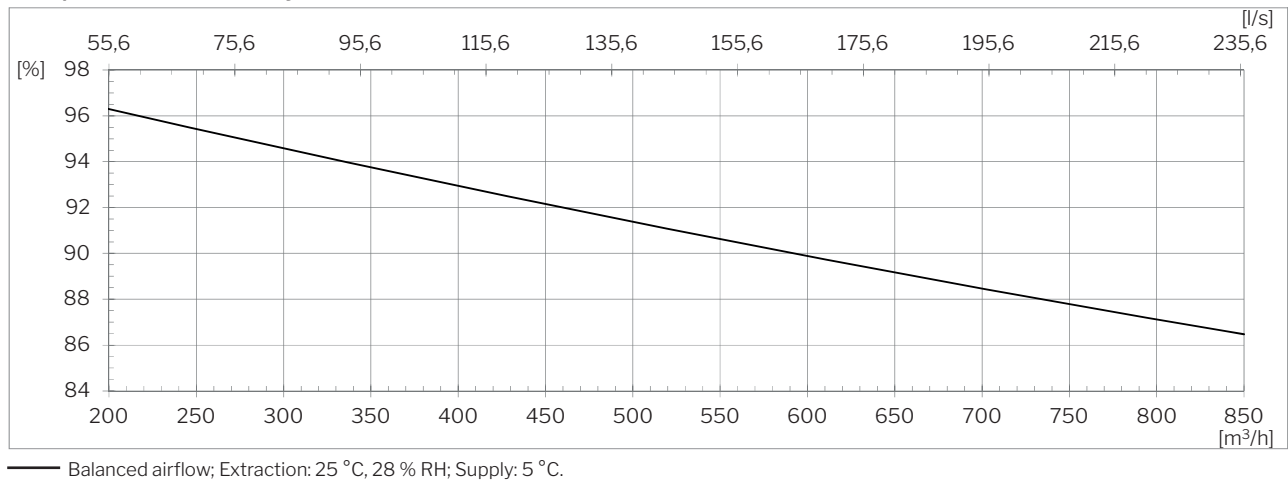

Power consumption ⁶

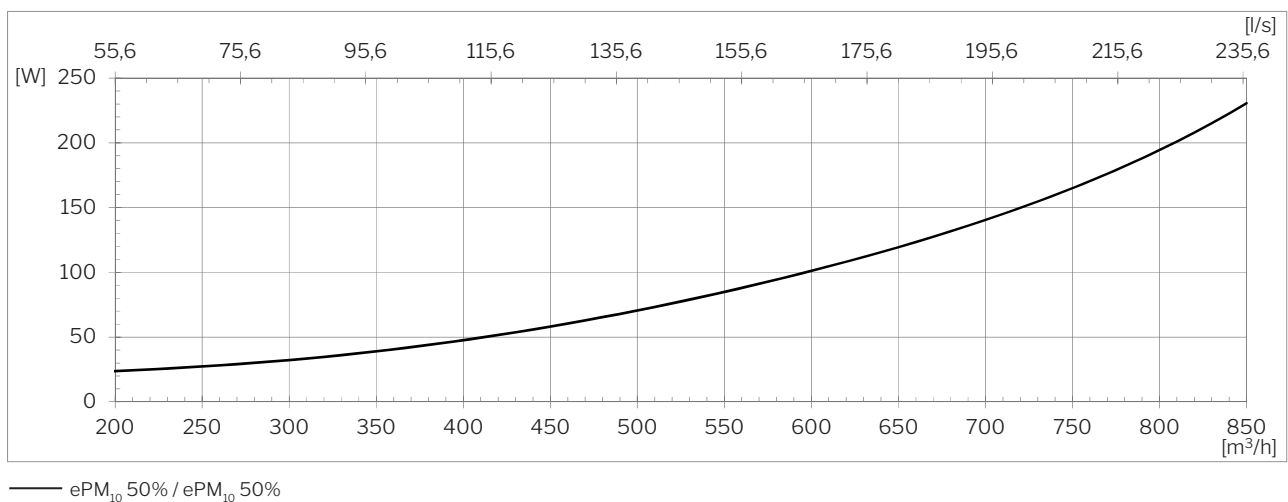

⁵Sound pressure level L_{p,eq} is measured in a height of 1.2 m with at horizontal distance of 1 m from the air handling unit in room with a size of 200 m³ and a reverberation time of T = 0.6 s, corresponding to a room attenuation of 7.5 dB.

⁶All measurements were performed in normal operating mode in a standard installation for the filter class, supply/extract air: ePM10 50% / ePM10 50%, using the facade grills recommended by Airmaster: Airmaster Boomerain® Ø315.

SFP⁷

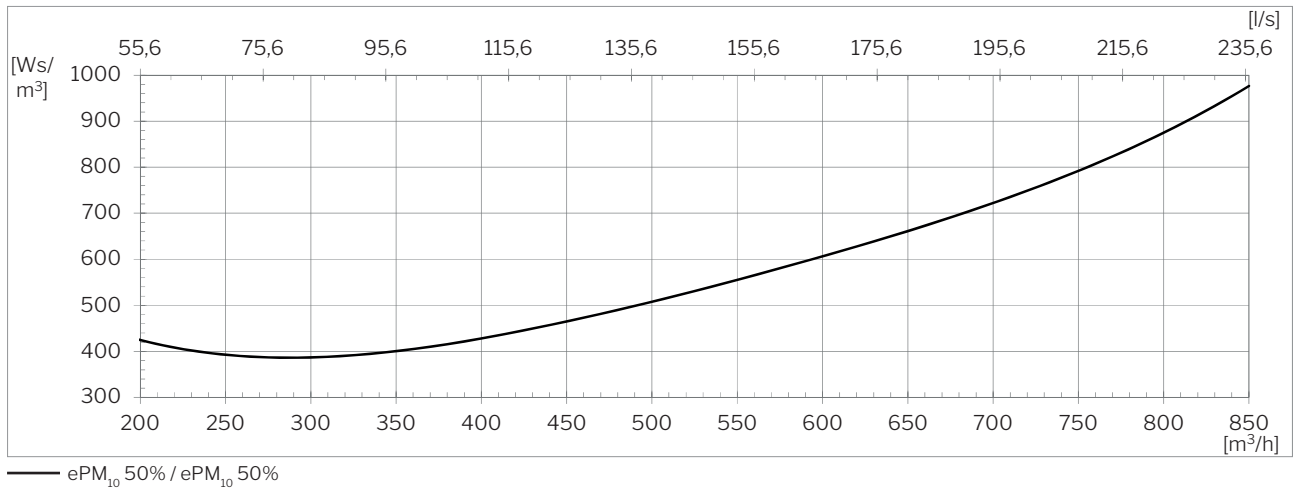

External pressure loss⁷

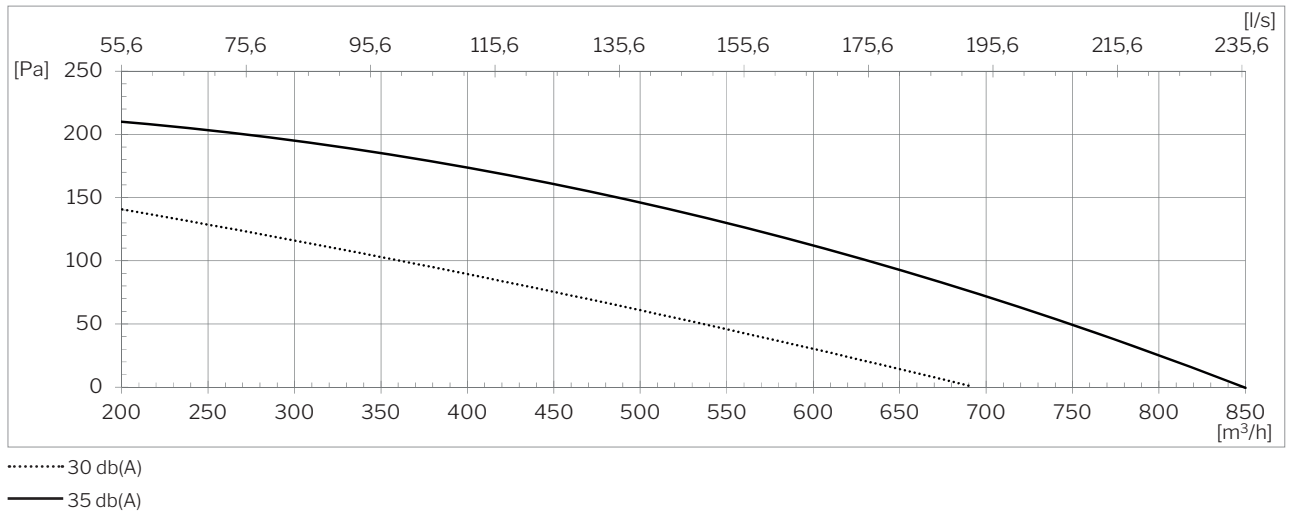

⁷ All measurements were performed in normal operating mode in a standard installation for the filter class, supply/extract air: ePM10 50% / ePM10 50%, using the facade grills recommended by Airmaster: Airmaster Boomerain® Ø315.

Adjacent zone⁸ - displacement

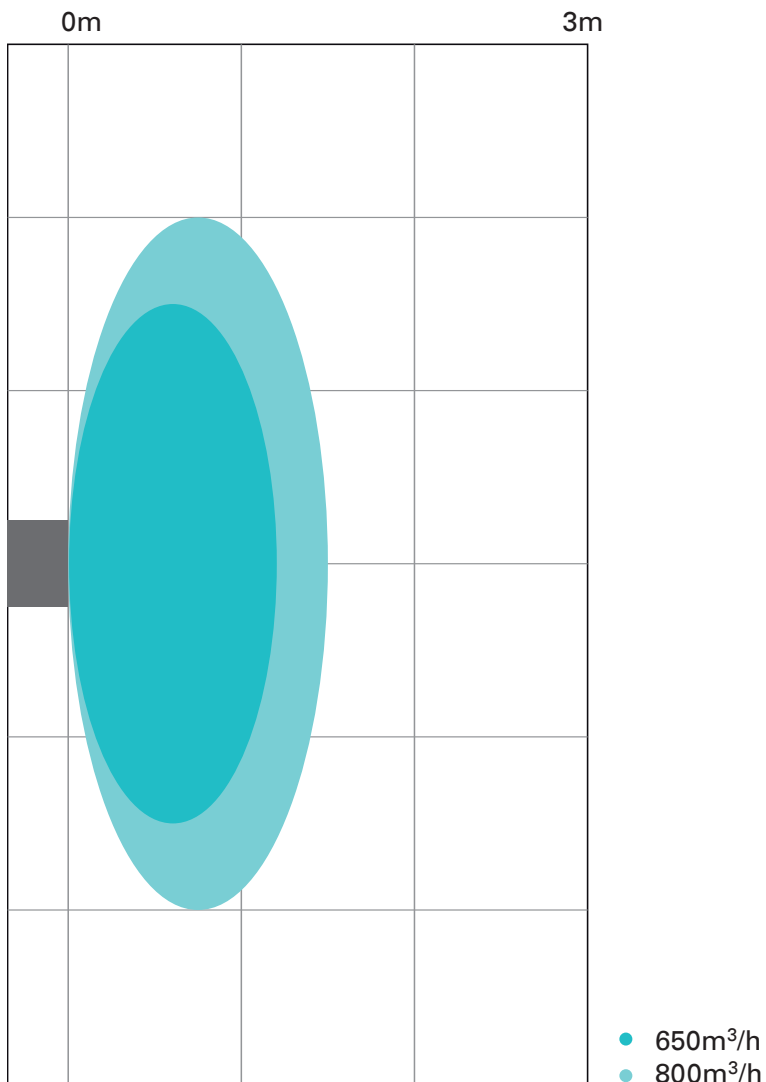

⁸ The result applies to an undertemperature of the inlet air of 3-5 °C.

Standard and options

Counterflow heat exchanger (PET)	x
Enthalpy counterflow heat exchanger (Polymer membrane)	o
Combination counterflow heat exchanger (Polymer membrane)	o
Motor-driven bypass	x
Motor-driven supply air damper	x
Motor-driven extract air damper	x
Capacitive return for motorized exhaust and supply air dampers	•
Electric preheating surface	•
Electric comfort heating surface	•
Water heating surface	o
Condensate pump	•
PIR/motion sensor (wall-mounted)	•
CO ₂ -sensor (wall-mounted)	•
CO ₂ -sensor (built-in)	•
TVOC-sensor (built-in)	•
CO ₂ -/TVOC-sensor (built-in)	•
Hygrostat	o

Energy meter	•
Supply air filter ePM ₁₀ 50%	•
Supply air filter ePM ₁ 55%	•
Supply air filter ePM ₁ 80%	o
Extract air filter ePM ₁₀ 50%	x
Boomerain® façade grille Ø315	•
Airlinq® Viva control panel	•
Airlinq® Orbit control panel	•
Airmaster Airlinq® Online	•
Airlinq® Online API	•
Airlinq® BMS	•
LON® module	o
KNX® module	o
MODBUS® RTU RS485 module	•
BACnet™ MS/TP module	•
BACnet™ /IP module	•

X : Standard • : Optional o : Special item

Schematic sketch - displacement

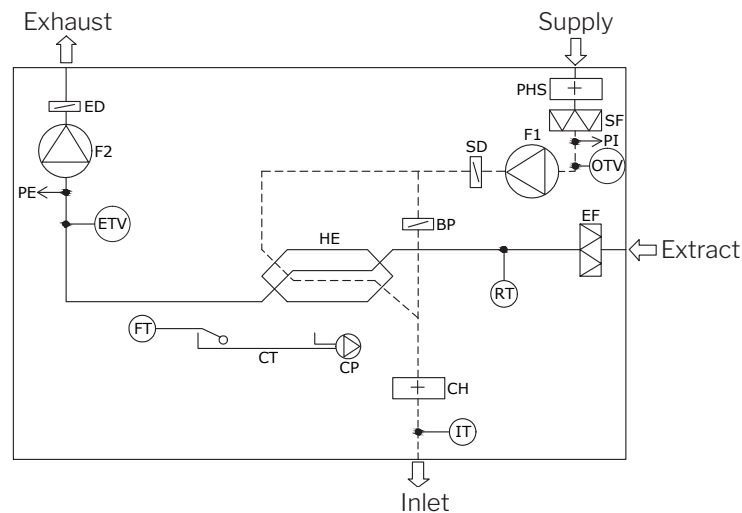

COMPONENT DESIGNATION

BP	Bypass damper (motor-driven)
CH	Electric comfort heating surface
CP	Condensate pump
CT	Condensate tray
ED	Exhaust air damper (motor-driven)
EF	Extract air filter

ETV	Exhaust temperature sensor
FT	Float
F1	Supply air fan
F2	Extract air fan
HE	Counterflow heat exchanger
IT	Inlet-air temperature sensor
OTV	Supply air temperature sensor

PE	Flow meter, extracted air (option)
PHS	Preheating surface (option)
PI	Flow meter, supply air (option)
RT	Room temperature sensor
SD	Supply air damper (Motor-driven)
SF	Supply air filter