

Airmaster Boomerain®

Product information

The Boomerain® grille is a patented wall grille, developed by Airmaster. It is a façade grille developed specifically to minimize pressure loss and associated noise while also minimizing water intake into the ventilation unit from both light and heavy rainfall.

The grille can be used in all kinds of ventilation systems where a wall-mounted intake/exhaust grille is utilized. There are three different types of Boomerain® grilles:

Boomerain® - 1



Boomerain® - 2

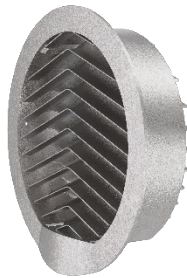

Boomerain® - 3

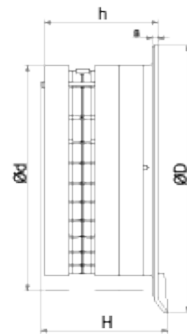
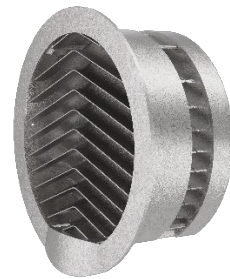

Boomerain®	Ød [mm]	ØD [mm]	h [mm]	H [mm]	Free area (A _f) [m ²]	Weight [kg]
Ø160-1	157	215	53	72	0.015	0.99
Ø160-2	157	215	104	118	0.015	1.47
Ø160-3	157	215	155	174	0.015	1.98
Ø200-1	197	255	53	72	0.024	1.31
Ø200-2	197	255	104	118	0.024	2.0
Ø200-3	197	255	155	174	0.024	2.71
Ø250-1	247	305	53	72	0.038	1.72
Ø250-2	247	305	126	140	0.038	2.66
Ø250-3	247	305	177	196	0.038	3.62
Ø315-1	312	370	53	72	0.0624	2.12
Ø315-2	312	370	104	118	0.0624	3.64
Ø315-3	312	370	155	174	0.0624	5

The choice of grille type depends on the risk of water penetrating the ventilation unit at the installation site.

A common requirement in tender material is that the air velocity through the intake grille should not exceed 2 – 2.5 m/s to avoid pulling water into the ventilation unit. Tests using the Boomerain® grille have shown that water ingress can be avoided at much higher air velocities due to the specialized design of the Boomerain® grille.

Additionally, tests have also shown that there is only a negligible difference between the pressure loss across the three types of Boomerain® grilles, despite their different appearances. This is due to the design of the Boomerain® grille which generates very little turbulence on the back of the grille.

Material and finish

- All grilles are made from cast aluminum.
- Standard finish: Untreated.
- Optional finish on request: Powder-coated RAL color.
- All grilles are available with a bird-net; the mesh size is 12x12 mm.

Maintenance

The bird net must be inspected regularly and objects such as leaves must be removed. The external parts should be wiped regularly with a damp cloth. The grille should be removed to gain access to the duct connected to the air handling unit.

Technical Data

The pressure loss of the Boomerain® grille is shown in the graphs below. The graphs for the three different grille types (1-3, above) have nearly identical data and therefore only one graph is shown for each grille type below. The graphs shown are for the grilles with the worst data and thus a "worst case" scenario.

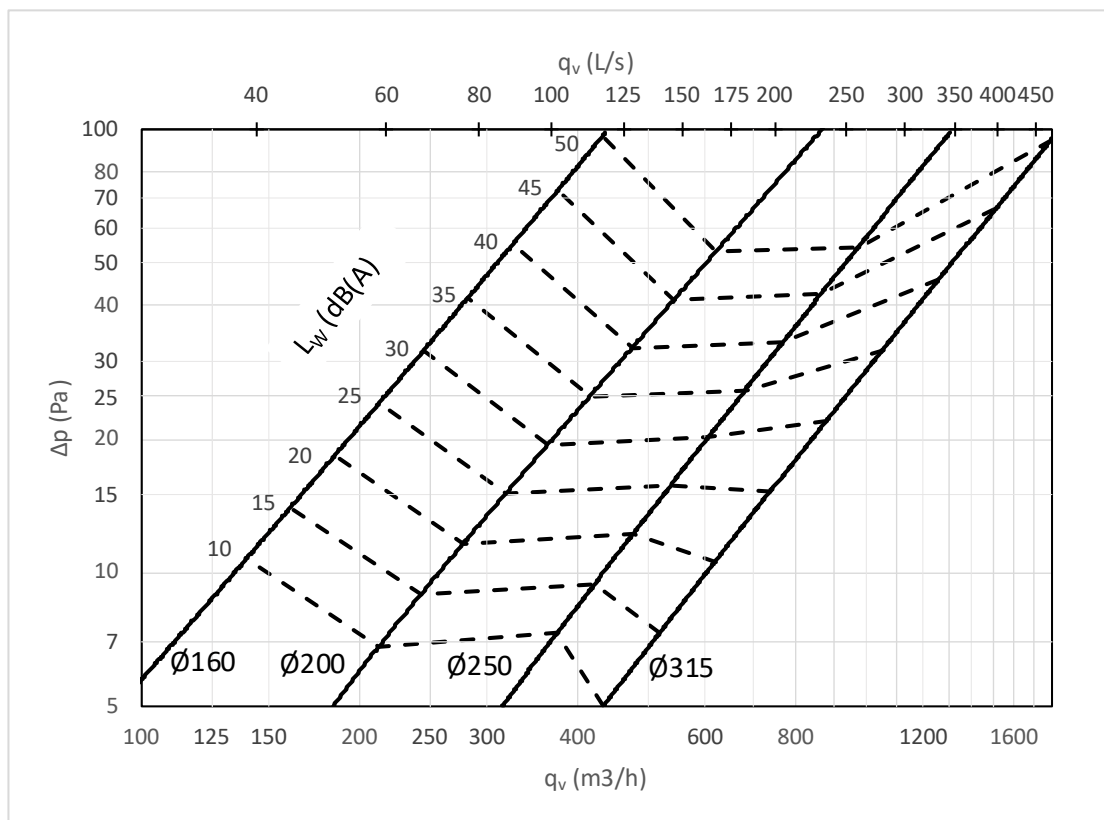

Figure 1: Airflow rate q_v [l/s]; [m³/h], pressure drop Δp [Pa], and sound power level LWA [dB(A)] are displayed in the graph.

Comparing a standard grille and an Airmaster Boomerain® grille

A CFD analysis comparing the Airmaster Boomerain® grille to the standard grille has been made. The two grilles are shown below.

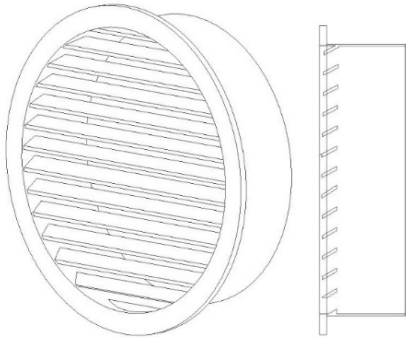

Figure 2: Standard grille, front and side view

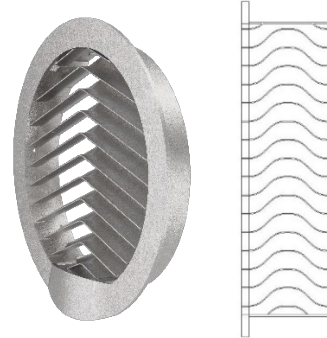

Figure 3: Boomerain grille, front and side view

The diagram below shows the velocity through the *standard grille* and inside the duct behind the mounted grille.

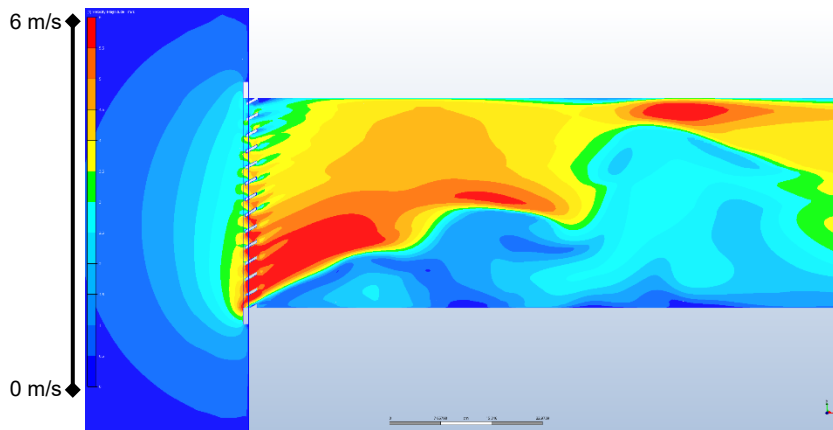

Figure 4: Airflow through a standard grille

The diagram below shows the velocity through the *Boomerain® grille* and inside the duct behind the mounted Boomerain® grille.

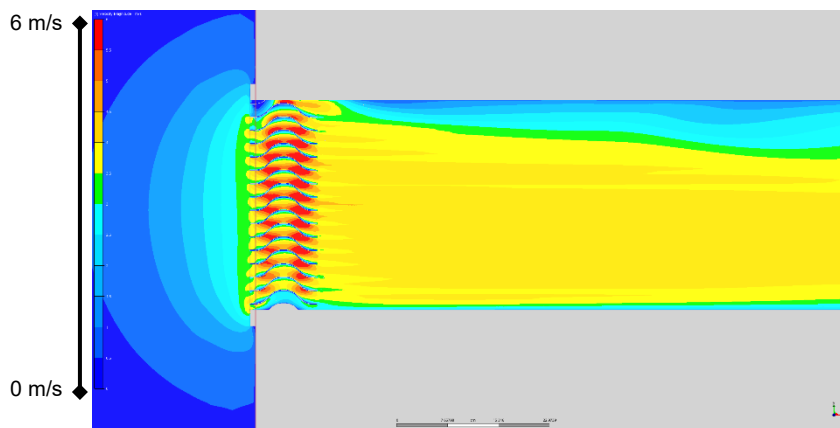

Figure 5: Airflow through a Boomerain® grille

The airflow through the Boomerain® grille is much more uniform and the air turbulence is likewise greatly reduced compared to the standard grille. This indicates that the Boomerain® has lower pressure loss and thus also lower sound levels overall compared to the standard grille.

Water penetration test

The three different types of Boomerain® grilles have been tested on water ingress, and the results have been compared to the standard grille. The results are shown in the graph below.

Tests were performed as a scenario that can be considered an *extreme* situation where the air is blown with wind speeds of 13 m/s against the grates with a rain intensity of 75 mm/h. The results are assessed under the diagram.

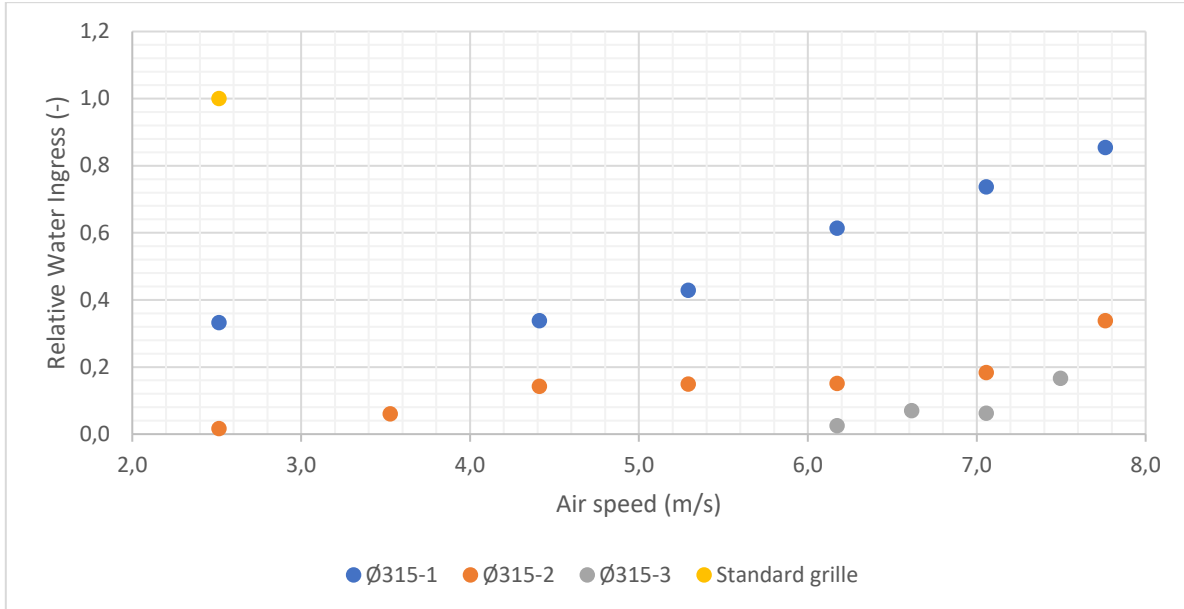

Figure 6: Results from testing air speed and water ingress on ventilation grilles

The yellow marker in the graph shows the water ingress for the standard grille with an air speed of 2.5 m/s through the grille. The relative value of the standard grille (the yellow dot) is used as reference value and therefore it is set to 1.0. All other values in the diagram are relative to the reference value in the above comparison.

The tests show that the risk of water ingress in the ventilation unit is significantly lowered with the Boomerain® grille compared to the standard grille.

For example, the water ingress for the standard grille at an air speed of 2.5 m/s through the grille is higher than a Boomerain® type-1 grille at an air speed of 7.8 m/s.

In summary: the benefits of the Boomerain® façade grille are not only a lower pressure loss but also a significantly lower risk of water ingress into the ventilation unit compared to a standard grille.

IMPORTANT

Surface characteristics for untreated aluminium grates.

The Boomerain grate is manufactured from untreated aluminium, which naturally reacts with oxygen in the atmosphere. Over time, this process leads to the formation of a white, powdery surface layer known as aluminium oxide. This is a normal and expected property of untreated aluminium exposed to outdoor environments, and it does not affect the structural integrity of the grate.

Please note that the appearance of the grate surface may be affected by the presence of particles such as concrete, lime, or similar alkaline substances. These materials may cause discoloration, stains, or promote surface changes due to chemical interactions.

In addition, the installation environment plays a significant role in the long-term aesthetics and surface condition of the grate. Exposure to seawater, airborne salt particles, industrial pollutants, or other chemically aggressive atmospheres can intensify surface reactions and lead to more pronounced changes in appearance.

It is also important to note that the white oxidation layer that forms on untreated aluminium may, over time, leave visible marks or streaks on the facade surface beneath the grate, especially in areas exposed to rain or heavy airflow.

For use in harsh or chemically active environments, or in cases where the natural white surface or any marks on the facade cannot be accepted, we strongly recommend the use of powder-coated aluminium grates. Powder coating provides enhanced protection against environmental influences and helps maintain a uniform visual appearance over time.