

The background of the page features a light gray gradient with two large, overlapping, wavy bands of fine, parallel lines. One band starts from the left edge and curves upwards and to the right, while the other starts from the top right and curves downwards and to the left, creating a sense of motion and depth.

# Installation


Electrical installation & network connection

AM 950 C | AM 950 F

AIRMASTER

This manual features texts, illustrations, and drawings that may not be replicated or otherwise circulated, even as excerpts, without express permission from Airmaster A/S.

Revision	Date	Description
01	2024-12-19	First edition.
02	2025-06-03	AM 950 C added. AME 900 F replaced with AM 950 F.
03	2025-11-26	AQC-P control box added.
03.1	2026-01-21	New design on back page.

	<b>NOTICE</b>
	<p>Read the manual thoroughly before installing the AM 950 units.</p> <p>Please keep it for later use. Manuals must be given to the owner of the unit for safekeeping.</p>

Fill out this form for future reference:

Installation information	
Type	
Delivery date	
Serial number	
Mounting location	

# Table of contents

1	Introduction .....	7
1.1	Target group .....	7
1.2	Warning symbols .....	7
1.3	Liability .....	8
2	Safety instructions.....	9
2.1	Responsibility.....	10
2.1.1	Personnel requirements .....	10
3	Product identification.....	11
3.1	AM 950 C.....	11
3.1.1	Product name and type .....	11
3.2	AM 950 F .....	11
3.2.1	Product name and type .....	11
3.3	Specifications for AM 950 C and AM 950 F .....	12
3.4	Options for AM 950 C and AM 950 F .....	12
3.4.1	Electric heating surfaces .....	12
3.4.2	Condensate pump .....	12
3.4.3	CO <sub>2</sub> sensor.....	12
3.4.4	TVOC sensor.....	12
3.4.5	CO <sub>2</sub> & TVOC sensor.....	13
3.4.6	PIR sensor.....	13
3.4.7	Smoke detector .....	13
3.4.8	Energy Meter, single-phase or three-phase .....	13
3.4.9	Network connections .....	13
3.4.10	Airlinq® Orbit control panel.....	13
3.4.11	Airlinq® Viva control panel .....	13
3.5	Manufacturer.....	13
4	Electrical installation.....	14
4.1.1	AQC-L box (black).....	14
4.1.2	AQC-P box (grey).....	14
4.2	Control box location on AM 950 C unit.....	15
4.3	Control box location on AM 950 F unit.....	16
4.4	Supply voltage .....	17
4.5	Data cable.....	18
4.5.1	Preparing the cable for the terminals.....	18
4.5.2	Shield termination.....	18
4.6	Wiring diagram AQC-L box (black) .....	19
4.7	Wiring diagram AQC-P box (grey) .....	21
4.8	External Start .....	23
4.8.1	AQC-L .....	23
4.8.2	AQC-P .....	23

4.9	External PIR sensor .....	24
4.9.1	AQC-L .....	24
4.9.2	AQC-P .....	24
4.10	External CO <sub>2</sub> sensor .....	25
4.11	External Stop .....	26
4.11.1	AQC-L .....	26
4.11.2	AQC-P .....	26
4.12	Boost .....	27
4.12.1	AQC-L .....	27
4.12.2	AQC-P .....	27
4.13	Energy Meter .....	28
4.13.1	Single-phase .....	28
4.13.2	Three-phase .....	28
4.14	Analog BMS .....	29
4.14.1	AQC-L .....	29
4.14.2	AQC-P .....	30
4.15	Alarm .....	30
4.16	Control panel – Airlinq® Orbit .....	31
4.16.1	AQC-L .....	31
4.16.2	AQC-P .....	32
4.16.3	Panel .....	32
4.17	Control panel – Airlinq® Viva .....	33
4.17.1	AQC-L .....	33
4.17.2	AQC-P .....	34
4.17.3	Panel .....	34
5	Airlinq BMS installation .....	35
5.1	DIP Switch .....	36
5.2	Jumper .....	36
5.2.1	AQC-L .....	36
5.2.2	AQC-P .....	36
5.3	Junction box .....	37
5.4	System programming .....	37
5.4.1	Units ID1 to ID19 .....	39
5.4.2	Group control panels for groups 1 to 19 .....	42
5.4.3	Unit ID0 .....	44
6	Network connections .....	46
6.1	Ethernet connection (for Airlinq® Online) .....	46
6.1.1	Test .....	46
6.1.2	Identification .....	46
6.1.3	Cable recommendation .....	46
6.1.4	Unit connections, AQC-L .....	46
6.1.5	Unit connections, AQC-P .....	47
6.1.6	Airlinq BMS + Airlinq® Online .....	47

6.2	MODBUS® RTU RS485 .....	48
6.2.1	Test .....	48
6.2.2	Addressing .....	48
6.2.3	Cable recommendation .....	48
6.2.4	Unit connections, AQC-L.....	49
6.2.5	Unit connections, AQC-P.....	49
6.3	BACnet™/IP .....	50
6.3.1	Test .....	50
6.3.2	Identification .....	50
6.3.3	Cable recommendation .....	50
6.3.4	Unit connections, AQC-L.....	51
6.3.5	Unit connections, AQC-P.....	51
6.4	BACnet™ MS/TP .....	52
6.4.1	Test .....	52
6.4.2	Addressing .....	52
6.4.3	Cable recommendation .....	52
6.4.4	Unit connections, AQC-L.....	53
6.4.5	Unit connections, AQC-P.....	53
7	Commissioning.....	54
Appendix A	Wiring diagrams for typical Airlinq BMS systems .....	55
	Individual units, one system control panel .....	55
	Combined system .....	56
Appendix B	Error descriptions .....	57

## Figures

Figure 1:	AM 950 C unit .....	11
Figure 2:	HH and VV version.....	11
Figure 3:	SSR version .....	11
Figure 4:	SSL version.....	11
Figure 5:	Access to the control box in the AM 950 C unit.....	15
Figure 6:	Access to the control box in the AM 950 F unit .....	16
Figure 7:	Shield termination .....	18
Figure 8:	AQC-L control box, standard configuration .....	19
Figure 9:	Databus RS485 (J16) and signal sources (J17).....	19
Figure 10:	BMS/Ethernet (J18), PC communication (J19), Jumper.....	19
Figure 8:	AQC-P control box, standard configuration .....	21
Figure 11:	Signal sources (J1), J2 currently not used, Databus RS485 (J3), PC connection (J4), BMS/Ethernet (J5) .....	21
Figure 12:	External Start, AQC-L .....	23
Figure 13:	External Start, AQC-P .....	23
Figure 14:	PIR sensor, AQC-L .....	24
Figure 15:	PIR sensor, AQC-P .....	24
Figure 16:	External CO <sub>2</sub> sensor, AQC-P .....	25
Figure 17:	External Stop, AQC-L.....	26
Figure 18:	External Stop, AQC-P .....	26
Figure 19:	Boost, AQC-L .....	27
Figure 20:	Boost, AQC-P.....	27
Figure 21:	Single-phase Energy Meter.....	28
Figure 22:	Three-phase Energy Meter .....	28

Figure 23: Analog BMS, AQC-L .....	29
Figure 24: Analog BMS, AQC-P .....	30
Figure 25: Alarm, AQC-P .....	30
Figure 26: Airlinq® Orbit panel .....	31
Figure 27: AQC-L and Orbit panel .....	31
Figure 28: AQC-P and Orbit panel .....	32
Figure 29: Orbit control panel installation .....	32
Figure 30: Airlinq® Viva panel .....	33
Figure 31: AQC-L and Viva panel .....	33
Figure 32: AQC-P and Viva panel .....	34
Figure 33: Viva control panel installation .....	34
Figure 34: Airlinq BMS installation overview .....	35
Figure 35: DIP Switch closed ("ON") .....	36
Figure 36: DIP Switch open ("OFF") .....	36
Figure 37: Jumper location, AQC-L .....	36
Figure 38: Jumper, AQC-L .....	36
Figure 39: Jumper location, AQC-P .....	36
Figure 40: Jumper, AQC-P .....	37
Figure 41: Ethernet, RJ45 .....	46
Figure 42: MAC address .....	46
Figure 43: Ethernet, unit connections, AQC-L .....	46
Figure 44: Ethernet, unit connections, AQC-P .....	47
Figure 45: Airlinq BMS and Airlinq® Online, unit connections .....	47
Figure 46: MODBUS®, unit connections, AQC-L .....	49
Figure 47: MODBUS®, unit connections, AQC-P .....	49
Figure 48: BACnet™ /IP .....	50
Figure 49: Network module ID example .....	50
Figure 50: BACnet™ /IP, unit connections, AQC-L .....	51
Figure 51: BACnet™ /IP, unit connections, AQC-P .....	51
Figure 52: BACnet™ MS/TP .....	52
Figure 53: BACnet™ MS/TP, unit connections, AQC-L .....	53
Figure 54: BACnet™ MS/TP, unit connections, AQC-P .....	53

## Tables

Table 1: Product name and type .....	11
Table 2: Product name and type .....	11
Table 3: AM 950 C and AM 950 F specifications .....	12
Table 4: AQC-L control box, standard configuration .....	20
Table 5: AQC-P control box, standard configuration .....	22
Table 6: Group 0 example .....	37
Table 7: Group 1 example .....	37
Table 8: System example .....	38
Table 9: Group control panel pairing table .....	38
Table 10: MODBUS® .....	48
Table 11: DIP switch settings .....	48
Table 12: MODBUS® addressing .....	48
Table 13: BACnet™ .....	52
Table 14: BACnet™ MS/TP .....	52

# 1 Introduction

This manual will give you instructions on how to install the AM 950 units (AM 950 C and AM 950 F) correctly and safely.

Mounting and installing an AM 950 unit is divided into two parts:

1. Electrical installation and network connection (this manual).
2. Mounting the unit. Please refer to the Mounting manual.

Both manuals are part of the delivery. The manuals can also be downloaded from our website, see section 3.5.





## 1.1 Target group

This manual is addressed to qualified personnel.


## 1.2 Warning symbols


This manual may contain warning symbols. The colors and symbols adhere to the ISO 3864 and ISO 7010 standards. The visual depiction may vary depending on the type of media.

The symbols are described below:

	<p style="text-align: center;"><b>DANGER</b></p> <p>Indicates a hazard with a high level of risk which, if not avoided, will result in death or serious injury.</p>
	<p style="text-align: center;"><b>WARNING</b></p> <p>Indicates a hazard with a medium level of risk which, if not avoided, could result in death or serious injury.</p>
	<p style="text-align: center;"><b>CAUTION</b></p> <p>Indicates a hazard with a low level of risk which, if not avoided, could result in minor or moderate injury.</p>
	<p style="text-align: center;"><b>CAUTION</b></p> <p>Wear safety footwear as personal protective equipment.</p>

*Continued on the next page*

	<b>NOTICE</b>
	Failure to comply with the instructions can damage the device and its environment.

	Information, tips, and recommendations.
---	---

### 1.3 Liability







The manufacturer cannot be held liable for damages due to usage violating this manual's instructions.

The manufacturer reserves the right to make changes without notice. All values stated are nominal values and may be affected by local conditions.


The warranty is voided should this manual not be followed.

## 2 Safety instructions

Breaching the instructions marked with a warning symbol carries a risk of personal injury or material damage.

	<p style="text-align: center;"><b>WARNING</b></p> <p>The electrical installation of an AM 950 unit may only be carried out by an authorized electrician or by Airmaster A/S.</p>
	<p style="text-align: center;"><b>WARNING</b></p> <p>The power supply must be switched off for all connections or service work. Make sure nobody turns the power on, and use the Lockout/Tagout procedure (LOTO).</p>
	<p style="text-align: center;"><b>WARNING</b></p> <p>Do not open the service cover/service door before disconnecting the unit's power supply.</p>
	<p style="text-align: center;"><b>CAUTION</b></p> <p>Do not start the unit before all service covers/service doors and grates on duct connections are fully installed.</p>
	<p style="text-align: center;"><b>CAUTION</b></p> <p>Wear safety shoes for personal protection.</p>
	<p style="text-align: center;"><b>NOTICE</b></p> <p>The unit must not operate without filters specified in the Operation &amp; Maintenance manual.</p>

## 2.1 Responsibility

<b>CAUTION</b>	
	<ul style="list-style-type: none"><li>• The installer is responsible for installing the unit following local legislation and regulations.</li><li>• The installer is responsible for making sure that all cables used for the installation are adjusted to the correct length/fit.</li><li>• Cables must be fixed to the cable tray to avoid loose cables in the unit.</li></ul>

### 2.1.1 Personnel requirements

The mounting and installation of the unit must be done by qualified personnel. Laypersons should not attempt to install an AM 950 unit.

### 3 Product identification

#### 3.1 AM 950 C

##### 3.1.1 Product name and type


Product name	AM 950 C
Unit item number	9000950601
Type	Decentral ventilation unit, ceiling/wall mounted
 <p>Figure 1: AM 950 C unit</p>	

Table 1: Product name and type

#### 3.2 AM 950 F

##### 3.2.1 Product name and type

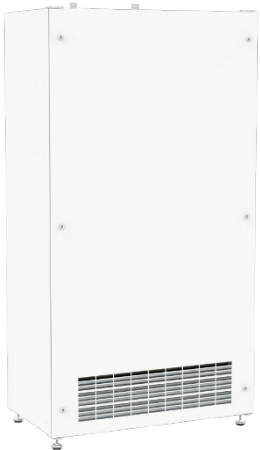
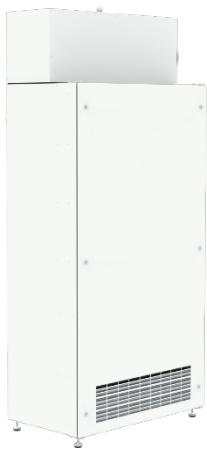

Product name	AM 950 F	
Unit item number	9000950701	
Type	Decentral ventilation unit, floor standing	
 <p>Figure 2: HH and VV version</p>	 <p>Figure 3: SSR version</p>	 <p>Figure 4: SSL version</p>

Table 2: Product name and type

### 3.3 Specifications for AM 950 C and AM 950 F

Supply voltage	220-240V/50Hz, ~1N+PE or 220-240V/50Hz, ~3N+PE*
Maximum power	354 W
Maximum current	2.76 A
Power factor	0.56
Maximum fuse	16 A, 1 phase, type B or 16 A, 3 phase, type B*
Leakage current AC / DC	≤6mA
Recommended residual current circuit breaker (RCCB)	Type F or Type B

Table 3: AM 950 C and AM 950 F specifications

\* A three-phase connection must be used if the electric preheating surface is chosen as an option.

Please refer to the AM 950 C or AM 950 F datasheet for further information. The datasheets are available on our website, see section 3.5 for more information.

### 3.4 Options for AM 950 C and AM 950 F

The AM 950 units can be equipped with options; please see below.

#### 3.4.1 Electric heating surfaces

The unit can be supplied with one or two built-in electric heating surfaces. Both the electric preheating surface and the electric comfort heating surface are optional; hence, the unit might have none, one, or two heating surfaces.

Note that electric heating surfaces consume more power. For further details, please see the data sheet.

Each electric heating surface is protected against overheating by two safety thermostats. The safety thermostats will disconnect the heating surfaces in the event of overheating.

One safety thermostat is equipped with an automatic reset, and the other is equipped with a manual reset. Please refer to the data sheets for further information.

#### 3.4.2 Condensate pump

The unit can be supplied with a condensate pump. The pump will drain the condensate tray, thereby eliminating the need for manually emptying the tray.

#### 3.4.3 CO<sub>2</sub> sensor

The unit can be supplied with a CO<sub>2</sub> sensor. The sensor output can be used to control the unit.

An external CO<sub>2</sub> sensor is available for both the AM 950 C and AM 950 F unit. This, however, requires an AQC-P control box.

#### 3.4.4 TVOC sensor

The unit can be supplied with a TVOC sensor. The sensor output can be used to control the unit.

### 3.4.5 CO<sub>2</sub> & TVOC sensor

The unit can be supplied with a combined CO<sub>2</sub> and TVOC sensor. The sensor output can be used to control the unit.

### 3.4.6 PIR sensor

The AM 950 C unit can be supplied with a PIR sensor (motion sensor) to detect motion in the room. The sensor output can be used to control the unit.

An external PIR sensor is available for both the AM 950 C and AM 950 F unit, but an internal PIR sensor is only available for the AM 950 C unit.

### 3.4.7 Smoke detector

The unit can be supplied with a built-in smoke detector. The smoke detector is designed to detect smoke inside ventilation ducts by means of a measuring tube. If smoke is detected, the smoke detector will stop the unit and raise an alarm.

### 3.4.8 Energy Meter, single-phase or three-phase

The unit can be supplied with an energy meter. The energy meter allows the user to monitor the unit's energy consumption.

### 3.4.9 Network connections

The unit can be supplied with plug-in cards for Ethernet, MODBUS<sup>®</sup> RTU RS485, BACnet<sup>™</sup>/IP, and BACnet<sup>™</sup> MS/TP.

### 3.4.10 Airlinq<sup>®</sup> Orbit control panel

The Airlinq<sup>®</sup> Orbit control panel provides a range of options to control the ventilation. The panel has touch functions and is usually installed in the same room as the unit. Please refer to section 4.16 for installation instructions.

### 3.4.11 Airlinq<sup>®</sup> Viva control panel

The Airlinq<sup>®</sup> Viva control panel is simple and user-friendly. The operation is automatic to minimize the risk of incorrect use. The panel has touch functions and is normally installed next to the unit. Please refer to section 4.17 for installation instructions.

## 3.5 Manufacturer


Airmaster A/S  
Industrivej 59  
9600 Aars  
Denmark

Phone: +45 98 62 48 22

E-mail: [info@airmaster.dk](mailto:info@airmaster.dk)

Web site: [www.airmaster.dk](http://www.airmaster.dk)

## 4 Electrical installation

<b>WARNING</b>	
	<ul style="list-style-type: none"><li>• Pay strict attention to section 2 before performing any type of electrical installation!</li><li>• Electrical equipment must be connected according to the wiring diagram in section 4.6.</li></ul>

Electrical equipment is connected to the unit's control box. The control box is either a black AQC-L box or a grey AQC-P box located inside the unit. Regardless of the control box, changes to the settings must be performed using a PC running the 'Airlinq Service Tool'.

'Airlinq Service Tool' can be downloaded from [www.airlinc.eu](http://www.airlinc.eu).

### 4.1.1 AQC-L box (black)

The control box has three analog inputs available:

- J17-5 (AI#1)
- J17-7 (AI#2)
- J17-11 (AI#3)

The inputs can be programmed to support different options, please refer to Table 4 on page 20. The AQC-L control box contains a varistor that protects against overvoltage.

Further options available:

- Airlinq® Orbit control panel. See section 4.16 for further information.
- Airlinq® Viva control panel. See section 4.17 for further information

### 4.1.2 AQC-P box (grey)

The control box has three digital inputs and three analog inputs available:

- J1-7 (DI#1)
- J1-6 (DI#2)
- J1-5 (DI#3)
- J1-14 (AI#1)
- J1-13 (AI#2)
- J1-12 (AI#3)

The inputs can be programmed to support different options, please refer to Table 5 on page 22.

Further options available:

- Airlinq® Orbit control panel. See section 4.16 for further information.
- Airlinq® Viva control panel. See section 4.17 for further information

## 4.2 Control box location on AM 950 C unit

You need to open the left-hand side service cover and the steel bottom plate to access the control box. Please refer to the drawings below:

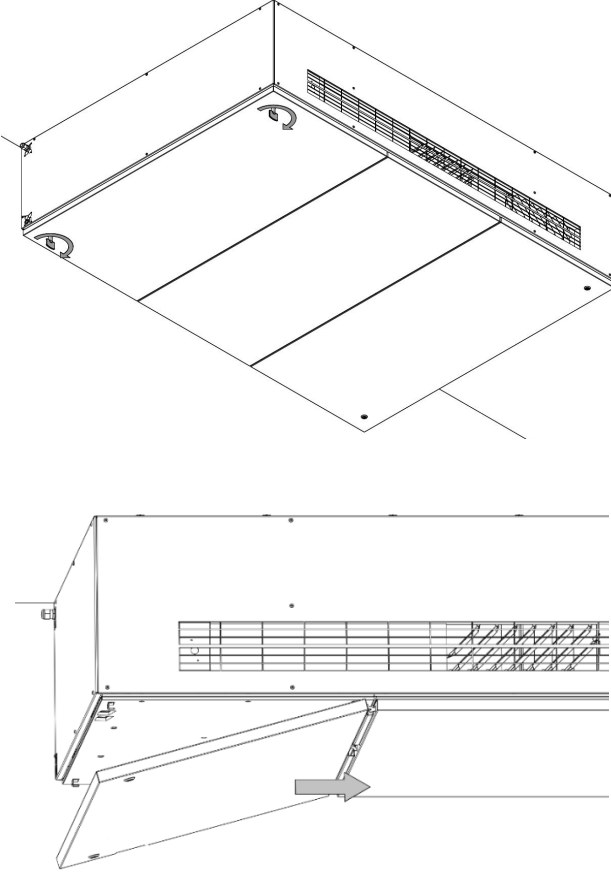
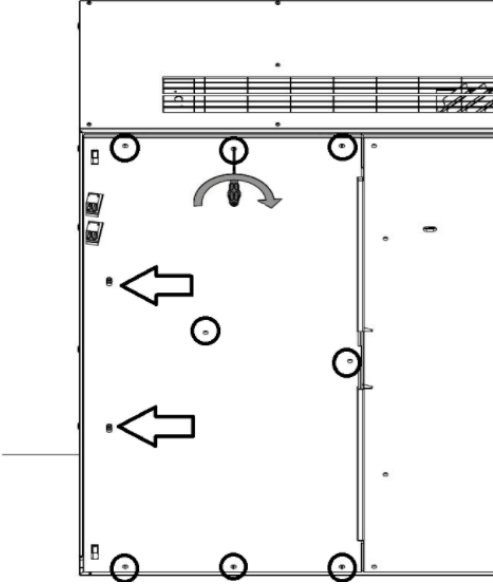
<p>Unlock and open the service cover.</p> <p>The service cover is designed to hang from the unit without falling.</p> <p><i>Take care not to bump into the service cover when it is hanging down.</i></p>	
<p>Unscrew the eight bolts marked with a circle.</p> <p>Loosen the bolts in the keyholes marked with an arrow.</p> <p>Push the steel plate towards the front of the unit so the bolts are in the wider part of the keyhole.</p> <p>The steel plate is designed to hang from the unit without falling.</p> <p>The control box is located in the front of the unit, above the cable tray.</p>	

Figure 5: Access to the control box in the AM 950 C unit

### 4.3 Control box location on AM 950 F unit

You need to open the service door and remove a cover plate to access the control box. Please refer to the drawings below:

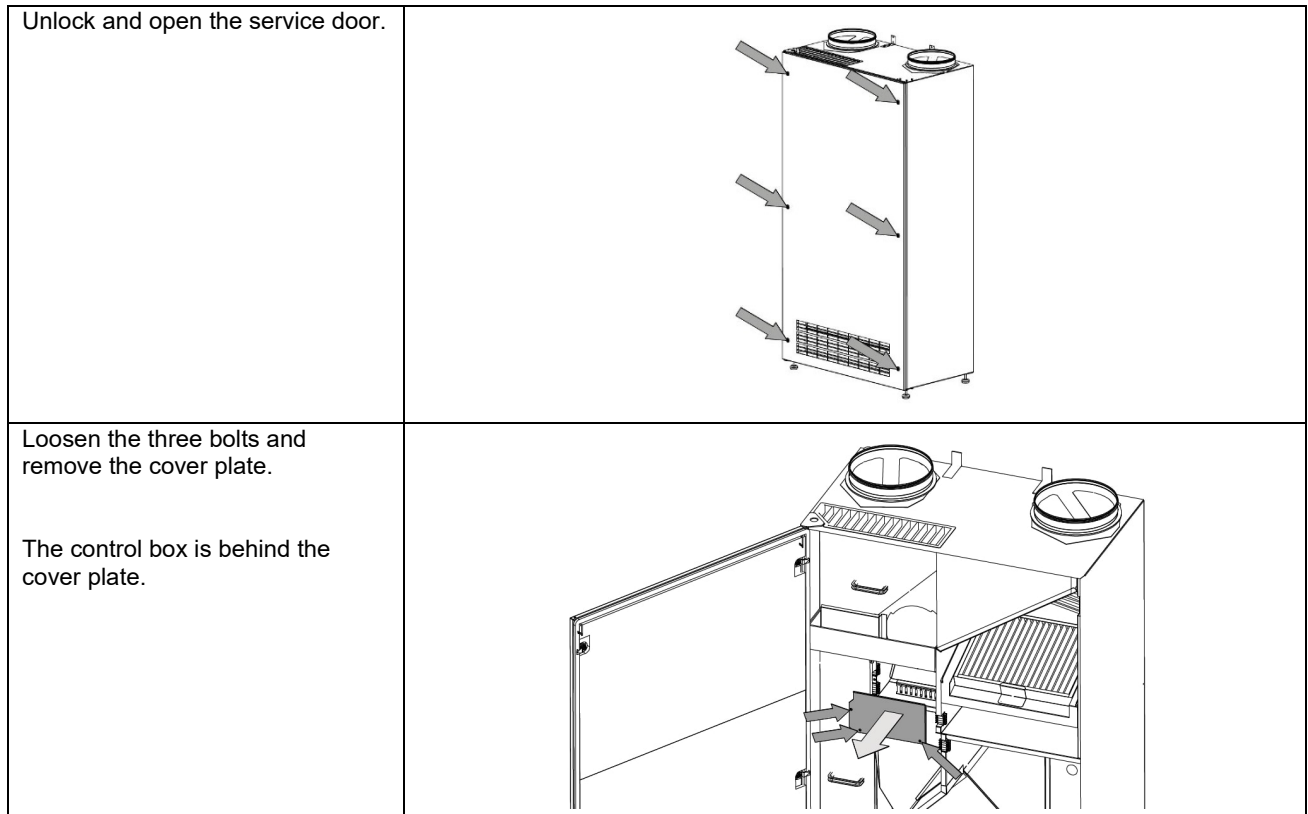



Figure 6: Access to the control box in the AM 950 F unit

## 4.4 Supply voltage

<b>CAUTION</b>	
	<ul style="list-style-type: none"><li>• Depending on the unit's power consumption and the existing electrical system, it may be necessary to set up at least one new power circuit.</li><li>• A pre-fuse and safety switch disconnecter must be fitted as part of the unit's permanent installation. The pre-fuse and safety switch is not part of Airmaster's delivery.</li><li>• The permitted leakage current per unit must be considered if more than one unit is installed.</li><li>• The supply cable must be dimensioned correctly. The conditions at the installation site must be taken into account.</li><li>• The control panel must be fitted before the supply voltage is connected.</li></ul>

## 4.5 Data cable

The connection cable for the control panel is a shielded twisted pair (STP) 2x2x0.6 data cable. Larger STP data cables can also be used. Sensors can also be connected with a non-twisted pair but shielded data cable.

### 4.5.1 Preparing the cable for the terminals

- Strip the insulation from the sheathing and shielding as close to the connection terminations as possible for reasons of EMC noise.
- Make sure you do not damage or break the leads when stripping the insulation.
- Maintain the twisted pairing of the leads right up to the terminals.
- Terminate the shield, see section 4.5.2 below.

### 4.5.2 Shield termination

To terminate the shield, follow the instructions below:

- Connect the drain wire to ground (GND) and cut away the shielding foil.

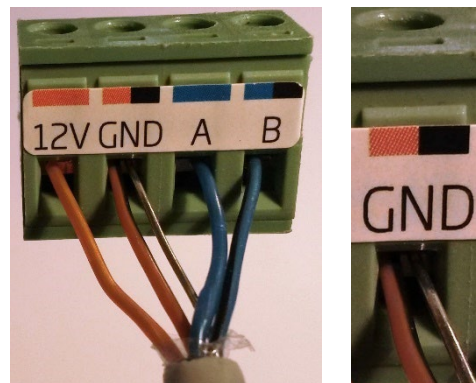



Figure 7: Shield termination

NOTICE	
	<ul style="list-style-type: none"><li>• The shield must be removed at the control panel.</li><li>• Do not over-tighten the screws.</li></ul>

## 4.6 Wiring diagram AQC-L box (black)

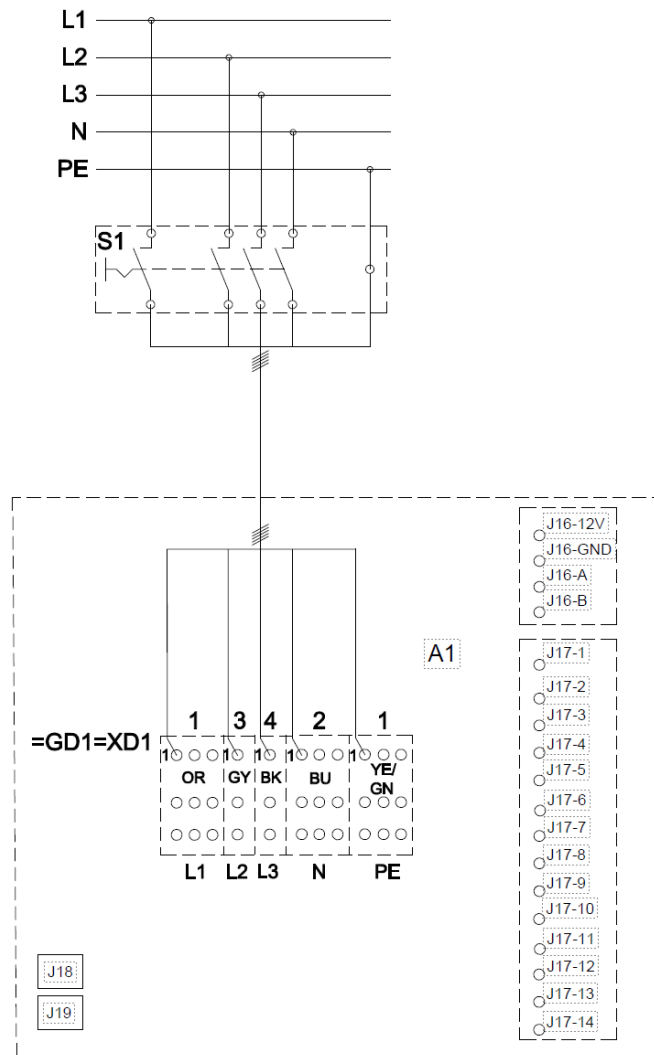


Figure 8: AQC-L control box, standard configuration

See Table 4 on the next page for a description.

Please refer to section 4.13 on page 28 if the unit is equipped with optional energy meters.

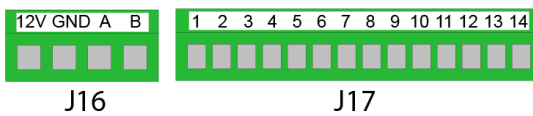


Figure 9: Databus RS485 (J16) and signal sources (J17)

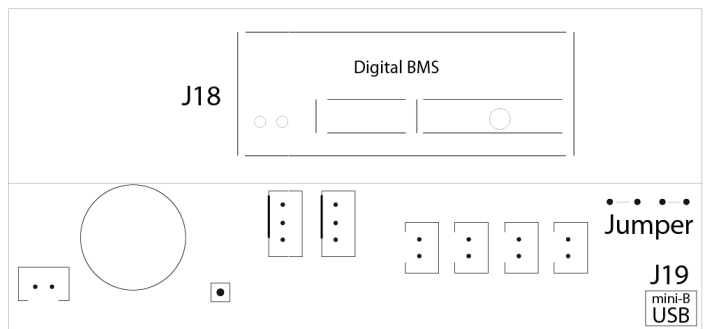


Figure 10: BMS/Ethernet (J18), PC communication (J19), Jumper

A1	Ventilation unit
=GD1=XD1	Terminal block, power supply
S1	Supply separator (not supplied by Airmaster)

<b>J16</b>	<b>Plug, control panel</b>
J16-12V	13.5 V (DC) output
J16-GND	GND
J16-A	+ RS485 (A)
J16-B	- RS485 (B)
<b>J17</b>	<b>Plug, I/O</b>
J17-1	13.5 V (DC) output
J17-2	-
J17-3	GND
J17-4	13.5 V (DC) output
J17-5 A/#1	<i>Default: PIR sensor</i> Optional: Boost, External Stop, A-BMS Start (input 0-10 V (DC) or 13.5 V (DC))
J17-6	GND
J17-7 A/#2	Boost, External Stop, A-BMS Flow or A-BMS Temperature (input 0-10 V (DC) or 13.5 V (DC))
J17-8	GND
J17-9	AO 2 Comfort heating surface or Alarm for preheating surface
J17-10	GND heating surface
J17-11 A/#3	<i>Default: External Start or Boost</i> Optional: External Stop, A-BMS Start (input 0-10 V (DC) or 13.5 V (DC))
J17-12	GND heating surface
J17-13	-
J17-14	AO 4 Preheating surface or Alarm for comfort heating surface
<b>J18</b>	<b>Plug, BMS: MODBUS<sup>®</sup>, BACnet<sup>™</sup>, Ethernet</b>
<b>J19</b>	<b>Plug, Mini-B USB (PC connection)</b>

L1	Phase
L2	Phase
L3	Phase
N	Neutral
PE	Protective Earth

BK	Black
BN	Brown
BU	Blue
GN	Green
OR	Orange
YE	Yellow

Table 4: AQC-L control box, standard configuration

## 4.7 Wiring diagram AQC-P box (grey)

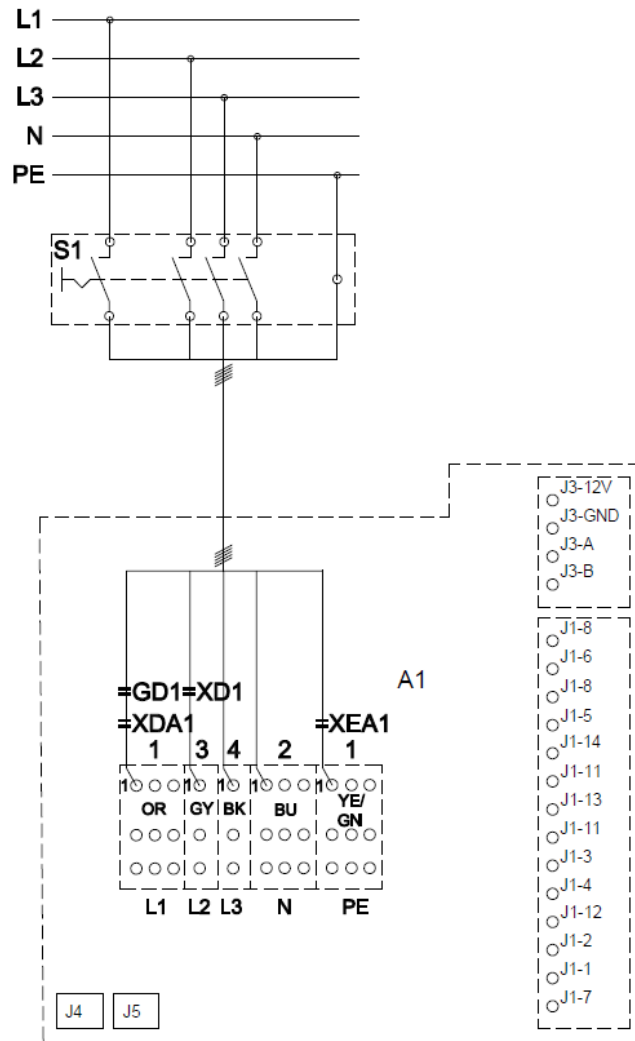


Figure 11: AQC-P control box, standard configuration

See Table 5 on the next page for a description.

Please refer to section 4.13 on page 28 if the unit is equipped with optional energy meters.

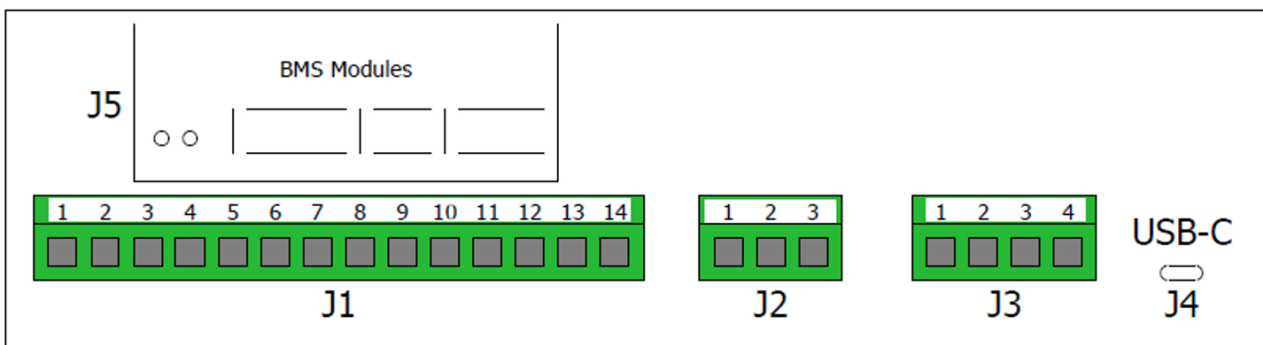


Figure 12: Signal sources (J1), J2 currently not used, Databus RS485 (J3), PC connection (J4), BMS/Ethernet (J5)

A1	Ventilation unit
=GD1=XD1	Terminal block, power supply
=XDA1	Terminal block, power supply
=XEA1	Terminal block, power supply
S1	Supply separator (not supplied by Airmaster)

<b>J1</b>	<b>Plug, I/O</b>
J1-1	24 V (DC) output
J1-2	GND
J1-3	Alarm terminal clamp 1 (COM)
J1-4	Alarm terminal clamp 2 (NO)
J1-5 DI#3	<i>Default: A-BMS Start or Boost</i> Optional: Digital input, External Stop
J1-6 DI#2	<i>Default: External Start</i> Optional: Digital input, Boost, External Stop
J1-7 DI#1	<i>Default: PIR sensor</i> Optional: Digital input, Boost, External Stop
J1-8	15 V (DC) output
J1-9	15 V (DC) output, default for PIR sensor
J1-10	GND PIR sensor
J1-11	GND (CO <sub>2</sub> sensor, A-BMS Flow, A-BMS Temperature)
J1-12 AI#3	<i>Default: CO<sub>2</sub> sensor input (input 0-10 V (DC))</i> Optional: External Start, External Stop, Boost, PIR
J1-13 AI#2	<i>Default: A-BMS Temperature input (input 0-10 V (DC))</i> Optional: External Start, External Stop, Boost, PIR
J1-14 AI#1	<i>Default: A-BMS Flow input - linear (input 0-10 V (DC))</i> Optional: External Start, External Stop, Boost, PIR
<b>J3</b>	<b>Plug, control panel</b>
J3-12V	15 V (DC) output
J3-GND	GND
J3-A	+ RS485 (A)
J3-B	- RS485 (B)
<b>J4</b>	<b>Plug, USB-C (PC connection)</b>
<b>J5</b>	<b>Plug, BMS: MODBUS<sup>®</sup>, BACnet<sup>™</sup>, Ethernet</b>

L1	Phase
L2	Phase
L3	Phase
N	Neutral
PE	Protective Earth

BK	Black
BN	Brown
BU	Blue
GN	Green
OR	Orange
YE	Yellow

Table 5: AQC-P control box, standard configuration

## 4.8 External Start

The AM 950 unit can be started by an external contact, e.g., a circuit breaker or a hygrostat. The unit is supplied with a low-voltage signal from the control box via the external contact. If the contact closes, the unit will start. If the signal is disrupted, the unit will stop.

### 4.8.1 AQC-L

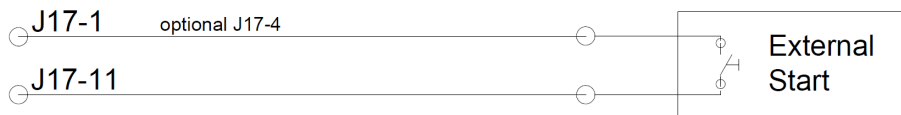


Figure 13: External Start, AQC-L

Connect the 13.5 V (DC) signal from terminal J17-1 to terminal J17-11 (AI#3) via the external start contact. Input AI#3 must be set to “external start” in ‘Airlinq Service Tool’.

### 4.8.2 AQC-P

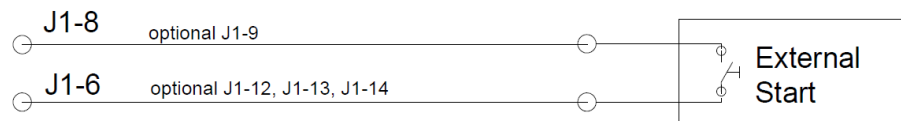


Figure 14: External Start, AQC-P

Connect the 15 V (DC) signal from terminal J1-8 to terminal J1-6 (DI#2) via the external start contact. Input DI#2 must be set to “external start” in ‘Airlinq Service Tool’.

Optionally, connect the 15 V (DC) signal from terminal J1-8 to terminal J1-12 (AI#3), J1-13 (AI#2), or J1-14 (AI#1) via the external start contact.

Input AI#1, AI#2, or AI#3 must be set to “external start” in ‘Airlinq Service Tool’.

## 4.9 External PIR sensor

The AM 950 unit can be started by the PIR sensor output.

### 4.9.1 AQC-L



Figure 15: PIR sensor, AQC-L

Connect the 13.5 V (DC) signal from terminal J17-4 to +12 V (DC) on the PIR sensor. Connect J17-5 (AI#1) and J17-1 to Alarm on the PIR sensor. Connect J17-6 to GND on the PIR sensor.

Input AI#1 must be set to "PIR" in 'Airlinq Service Tool'.

### 4.9.2 AQC-P

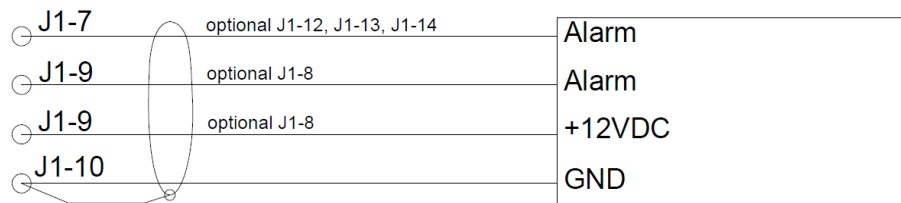


Figure 16: PIR sensor, AQC-P

Connect the 15 V (DC) signal from terminal J1-9 to +12 V (DC) on the PIR sensor. Connect J1-7 (DI#1) and J1-9 to Alarm on the PIR sensor. Connect J1-10 to GND on the PIR sensor.

Input DI#1 must be set to "PIR" in 'Airlinq Service Tool'.

Optionally, connect J1-12 (AI#3), J1-13 (AI#2), or J1-14 (AI#1) to Alarm on the PIR sensor. Input AI#1, AI#2, or AI#3 must be set to "PIR" in 'Airlinq Service Tool'.

## 4.10 External CO<sub>2</sub> sensor

The AM 950 unit can be started and controlled by an external CO<sub>2</sub> sensor output. This, however, is *only available with an AQC-P control box*.

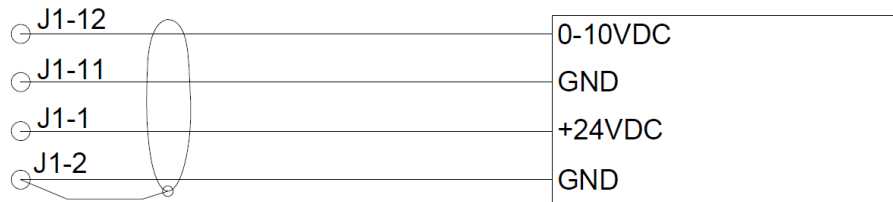


Figure 17: External CO<sub>2</sub> sensor, AQC-P

Connect the 24 V (DC) signal from terminal J1-1 to +24 V (DC) on the CO<sub>2</sub> sensor. Connect J1-12 (AI#3) to 0-10V (DC) on the CO<sub>2</sub> sensor. Connect J1-2 and J1-11 to GND on the CO<sub>2</sub> sensor.

Input AI#3 must be set to "CO<sub>2</sub>" in 'Airlinq Service Tool'.

## 4.11 External Stop

The “External Stop” function can shut down the AM 950 unit independently of other start signals, e.g., in case of an emergency. The signal must go through a potential-free NO relay (normally open), e.g. a smoke detector.

The unit is supplied with a low-voltage signal from the control box via the NO relay. To keep the unit in operation the low voltage signal must continue, i.e., the relay must stay closed. If the signal is disrupted, i.e., the relay opens, the unit will stop immediately regardless of operating status.

The AM 950 unit is started by the programmed start signals.

### 4.11.1 AQC-L

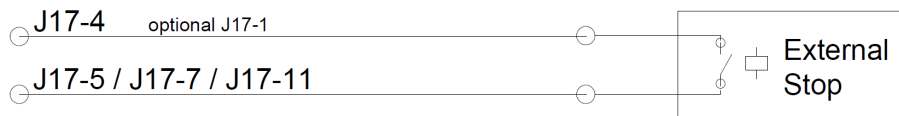


Figure 18: External Stop, AQC-L

Connect the 13.5 V (DC) signal from terminal J17-4 to terminal J17-5 (AI#1), J17-7 (AI#2), or J17-11 (AI#3) via the external stop NO relay.

Input AI#1, AI#2, or AI#3 must be set to “External Stop” in ‘Airlinq Service Tool’.

### 4.11.2 AQC-P

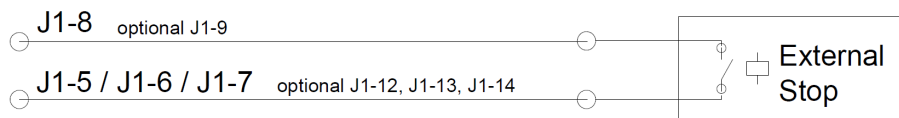


Figure 19: External Stop, AQC-P

Connect the 15 V (DC) signal from terminal J1-8 to terminal J1-5 (DI#3), J1-6 (DI#2), or J1-7 (DI#1) via the external stop NO relay.

Input DI#3, DI#2, or DI#1 must be set to “External Stop” in ‘Airlinq Service Tool’.

Optionally, connect the 15 V (DC) signal from terminal J1-8 to terminal J1-12 (AI#1), J1-13 (AI#2), or J1-14 (AI#3).

Input AI#1, AI#2 or AI#3, must be set to “External Stop” in ‘Airlinq Service Tool’.

## 4.12 Boost

You can adjust the unit's airflow temporarily by means of the Boost functionality. This can be done via a NO contact (normally open).

When activating the contact, i.e., closing it, the unit stops normal operation and activates the boost function. If the signal is disrupted, the unit will return to the previous operating mode. In case the unit is stopped, the unit will start when the contact is activated.

The function is programmed with fixed control voltages for both the inlet and the exhaust fan and, if relevant, after run time. It is possible to adjust the control voltages for the fans independently if unbalanced ventilation is required.

### 4.12.1 AQC-L

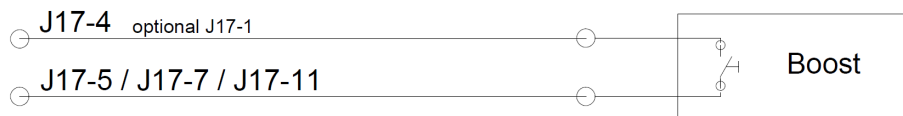


Figure 20: Boost, AQC-L

Connect the 13.5 V (DC) signal from terminal J17-4 to terminal J17-5 (AI#1), J17-7 (AI#2), or J17-11 (AI#3) via the external NO contact.

Input AI#1, AI#2, or AI#3 must be set to "Boost" in 'Airlinq Service Tool'. The control voltages and, if relevant, after run time for the function must be programmed as well.

### 4.12.2 AQC-P

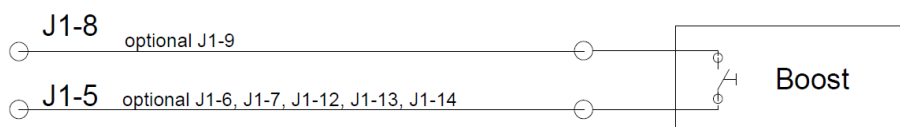


Figure 21: Boost, AQC-P

Connect the 15 V (DC) signal from terminal J1-8 to terminal J1-5 (DI#3) via the external NO contact.

Input DI#3 must be set to "Boost" in 'Airlinq Service Tool'. The control voltages and, if relevant, after run time for the function must be programmed.

Optionally, connect the 15 V (DC) signal from terminal J1-8 to terminal J1-6 (DI#2), J1-7 (DI#1), J1-12 (AI#3), J1-13 (AI#2) or J1-14 (AI#1) via the external NO contact.

## 4.13 Energy Meter

The energy meter installation is the same in the AQC-L and AQC-P control box.

### 4.13.1 Single-phase

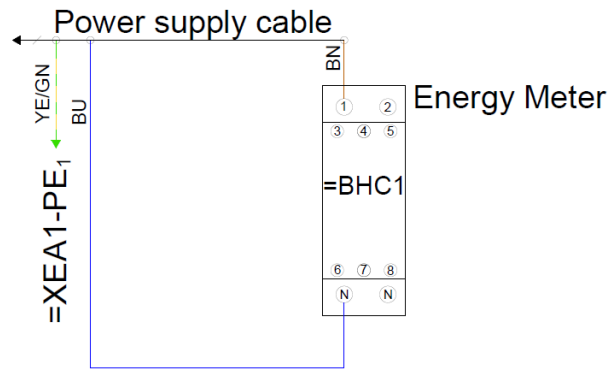


Figure 22: Single-phase Energy Meter

Connect the phase and neutral directly into the Energy Meter instead of the terminal block.

Terminate PE in the terminal block.

### 4.13.2 Three-phase

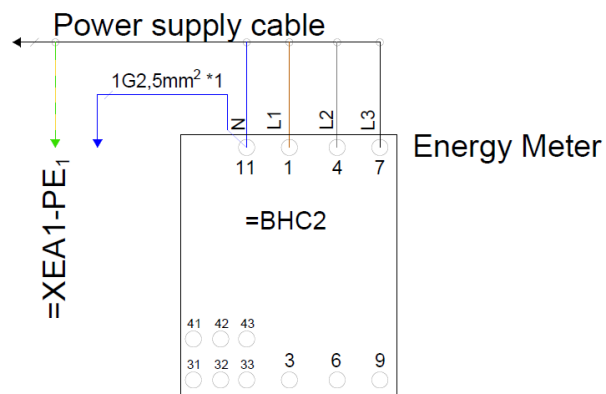


Figure 23: Three-phase Energy Meter

Connect the phases and neutral directly into the Energy Meter instead of the terminal block.

Terminate PE in the terminal block.

## 4.14 Analog BMS

The AM 950 unit can be connected to an analog Building Management System (A-BMS). The unit will then start and stop according to the A-BMS system's programming.

If you only wish to start or stop the unit using A-BMS, this is also possible. By doing this, the unit will operate according to the airflow and inlet temperature set on the control panel or parameters set by, e.g., a CO<sub>2</sub> sensor.

- A-BMS Start: NO relay (normally open). This starts and stops the unit according to the BMS system.
- A-BMS Flow: Airflow control. Potential-free 0-10 volt signal. Controlled by the A-BMS.
- A-BMS Temperature: Inlet air temperature control. Potential-free 0-10 volt signal. Controlled by the A-BMS.

### 4.14.1 AQC-L



Figure 24: Analog BMS, AQC-L

The A-BMS system passes the 13.5 V (DC) output signal from terminal J17-4 to terminal J17-5 (AI#1) via a NO relay. The airflow is controlled by a potential-free 0-10 volt signal on terminal J17-7 (AI#2) and GND on terminal J17-8. The inlet air temperature is controlled by a potential-free 0-10 volt signal on terminal J17-11 (AI#3) and GND on terminal J17-8.

If you only wish to use the A-BMS to start/stop the unit, you need to connect the start signal to 'External Start', see section 4.8.1 on page 23. You do not need to connect flow and temperature.

Input AI#1 must be set to "A-BMS Start", input AI#2 to "A-BMS Flow", and input AI#3 to "A-BMS Temp" in 'Airlinq Service Tool'.

### 4.14.2 AQC-P

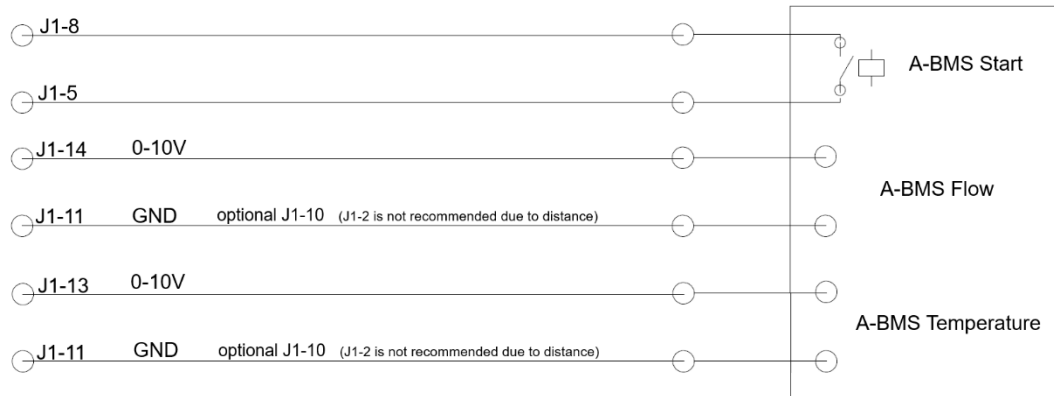


Figure 25: Analog BMS, AQC-P

The A-BMS system passes the 15 V (DC) output signal from terminal J1-8 to terminal J1-5 (DI#3) via a NO relay. The airflow is controlled by a potential-free 0-10 volt signal on terminal J1-14 (AI#1) and GND on terminal J1-11. The inlet air temperature is controlled by a potential-free 0-10 volt signal on terminal J17-13 (AI#2) and GND on terminal J1-11.

If you only wish to use the A-BMS to start/stop the unit, you need to connect the start signal to 'External Start', see section 4.8.2 on page 23. You do not need to connect flow and temperature.

Input DI#3 must be set to "A-BMS Start", input AI#1 to "A-BMS Flow", and input AI#2 to "A-BMS Temp" in 'Airlinq Service Tool'.

### 4.15 Alarm

The alarm function is only available on the AQC-P control box.

If one or more alarms in the AM 950 unit is activated this function will send out an alarm signal. The alarm signal does not include information on how many alarms have gone off, neither does it include information about what the alarm was triggered by.

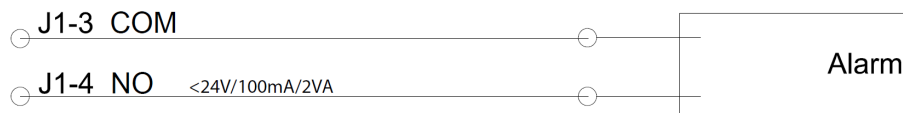


Figure 26: Alarm, AQC-P

## 4.16 Control panel – Airlinq® Orbit

The Airlinq® Orbit control panel is an option and might not be part of the delivery.



Figure 27: Airlinq® Orbit panel

Mount the control panel at a suitable height on the wall, usually in the same room as the AM 950 unit. It may, however, be placed in an adjacent room.

	<b>NOTICE</b>
	Leave at least 50 mm to the nearest obstacle when mounting the panel.

### 4.16.1 AQC-L

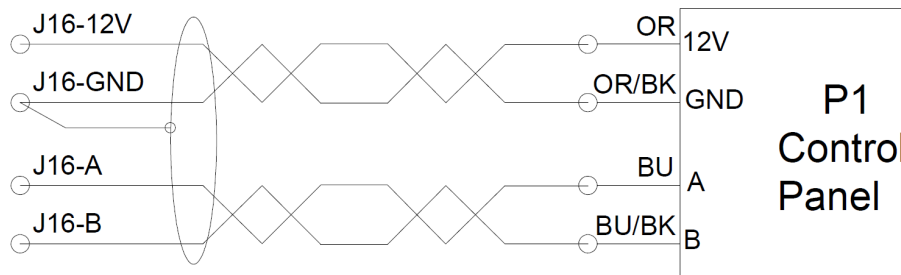


Figure 28: AQC-L and Orbit panel

### 4.16.2 AQC-P

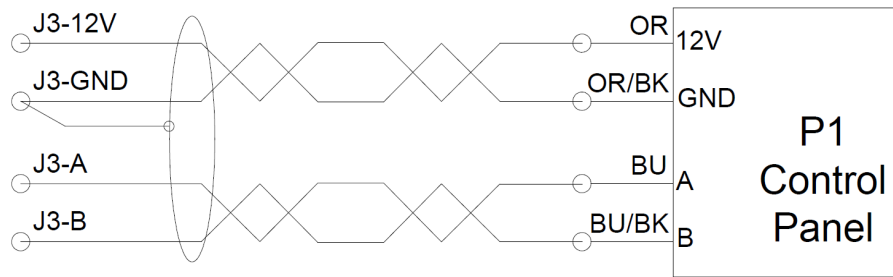



Figure 29: AQC-P and Orbit panel

### 4.16.3 Panel

NOTICE	
	Leads for A/B and 12 V/GND must be shielded twisted pair. Remove the shield carefully to prevent short-circuiting.

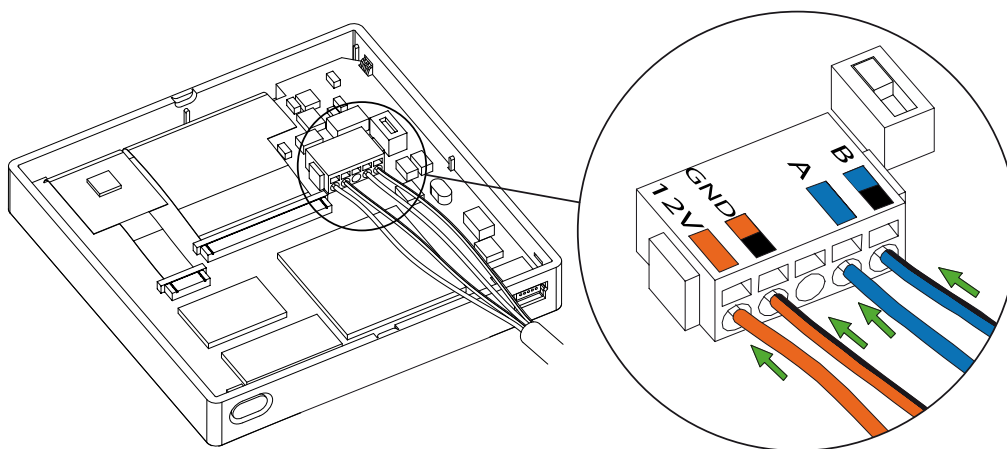


Figure 30: Orbit control panel installation


## 4.17 Control panel – Airlinq® Viva

The Airlinq® Viva control panel is an option and might not be part of the delivery.



Figure 31: Airlinq® Viva panel

Mount the control panel at a suitable height on the wall, usually in the same room as the AM 950 unit. It may, however, be placed in an adjacent room.

NOTICE	
	Leave at least 50 mm to the nearest obstacle when mounting the panel.

### 4.17.1 AQC-L

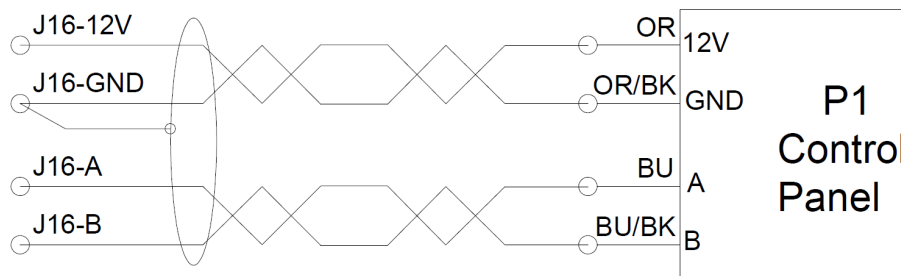


Figure 32: AQC-L and Viva panel

### 4.17.2 AQC-P

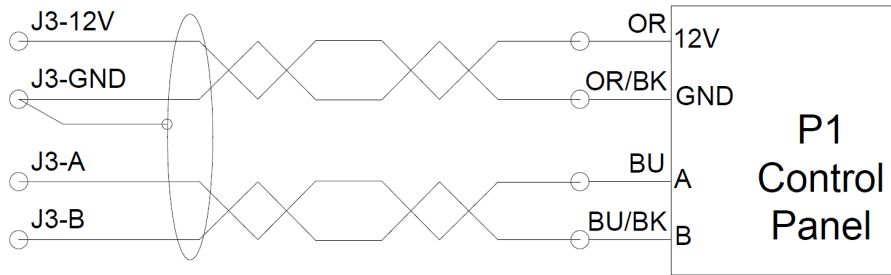



Figure 33: AQC-P and Viva panel

### 4.17.3 Panel

NOTICE	
	<p>Leads for A/B and 12 V/GND must be shielded twisted pair. Remove the shield carefully to prevent short-circuiting.</p>

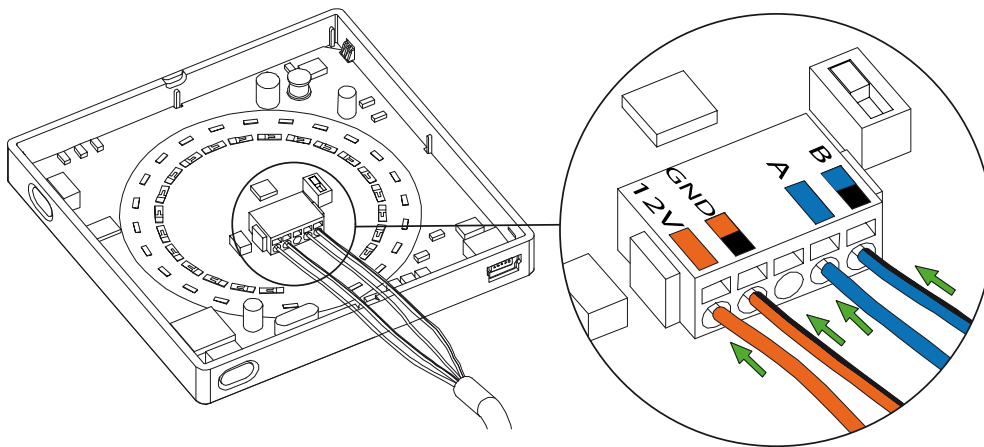


Figure 34: Viva control panel installation

# 5 Airlinq BMS installation

Please note that this section is a generic description of Airlinq BMS.

Airlinq BMS can control up to 20 Airmaster units and 20 Airmaster cooling modules, including up to 19 group control panels from one single Airlinq® Orbit system control panel.


	NOTICE
<p>Please note that all units <i>must</i> have an identical software version.</p>	

Figure 35 displays a generic overview of an Airlinq BMS installation.

The control panel is connected to a unit via a data cable (see section 4.5 on page 18). The units are connected by a shielded twisted pair data cable (STP 2x0.6). Note that the shield on each cable must only be connected at one end! The maximum system cable length is 1000 m. Wiring must be connected according to BMS standards.

Please contact Airmaster beforehand if more than 100 m of data cable is needed to install a control panel.

The first and last units must be terminated in a DIP Switch or a Jumper. None of the other units may be terminated. The control panel can be connected as the first or last unit in the chain.

The DIP switch is located on the Airlinq® Orbit control panel, see section 5.1 for further information. The Jumper is located on the control box, see section 5.2 for further information.

The system is programmed using a PC running the 'Airlinq Service Tool'.

System:

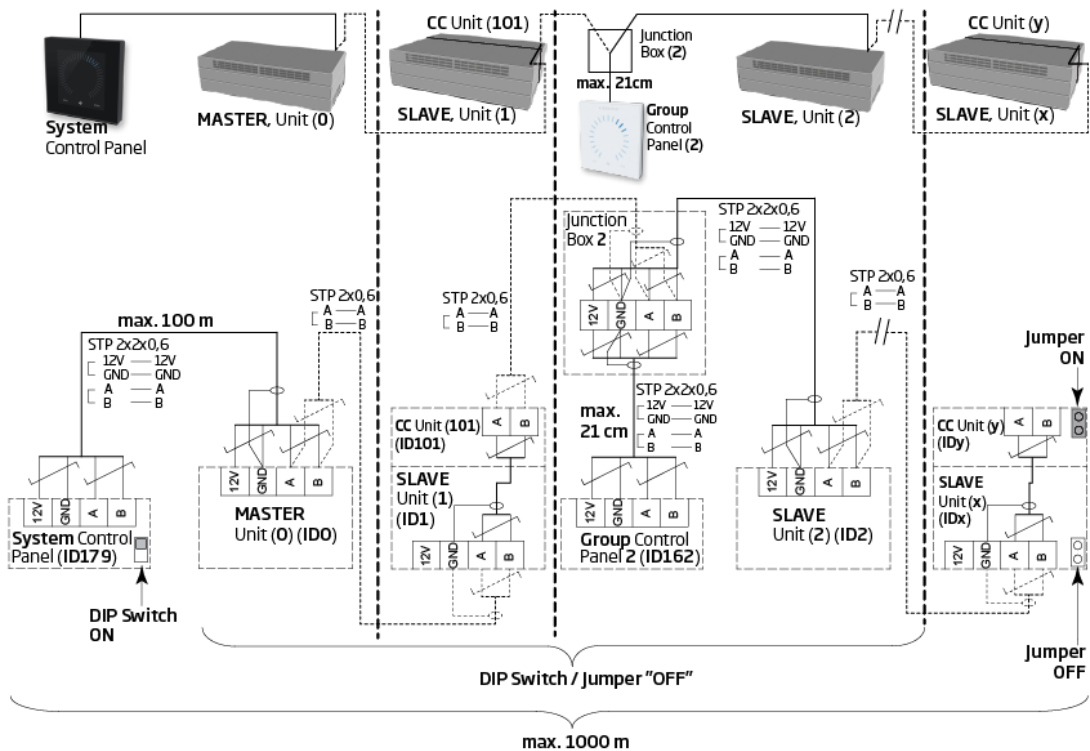


Figure 35: Airlinq BMS installation overview

Appendix A shows more examples of typical Airlinq BMS systems.

## 5.1 DIP Switch

The DIP Switch is located in the Orbit control panel, see Figure 30 on page 32 for reference. As default, the DIP switch is "ON".

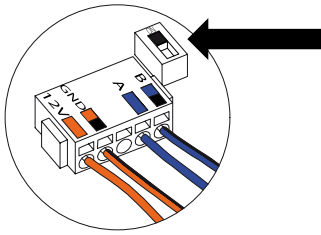


Figure 36: DIP Switch closed ("ON")

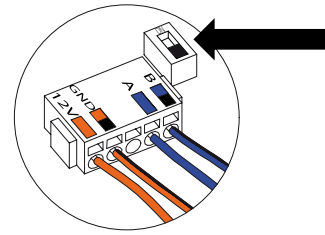


Figure 37: DIP Switch open ("OFF")

## 5.2 Jumper

### 5.2.1 AQC-L

The jumper on the AQC-L box is located on the side of the box, see Figure 38 below.

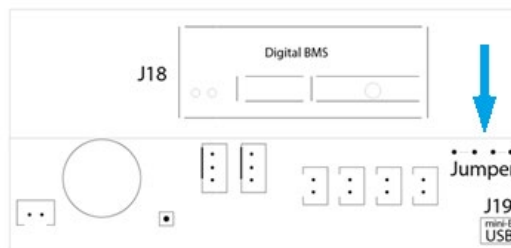


Figure 38: Jumper location, AQC-L

The jumper is default open ("OFF").



Figure 39: Jumper, AQC-L

### 5.2.2 AQC-P

The jumper on the AQC-P box is located *inside* the control box, behind J3, see Figure 40. You need to loosen the four screws in each corner of the control box and remove the top to access it.

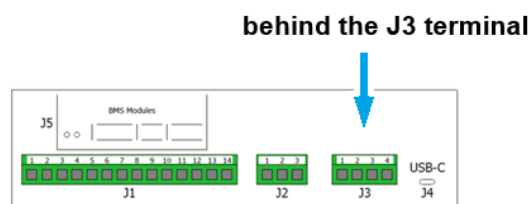


Figure 40: Jumper location, AQC-P

The jumper is default open ("OFF").

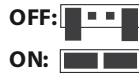


Figure 41: Jumper, AQC-P

### 5.3 Junction box

The junction box must be installed near the control panel. Cables over 21 cm are not permitted and may lead to communication errors.

### 5.4 System programming

Units in an Airlinq BMS system must be grouped. Each group has its own Group ID. The first group is G0, then G1, G2,...G19. You can have a maximum of 20 groups [0-19] in the system; however, this would mean that each group consists of one unit only, as the maximum number of units in one system is 20.

Each group must have a 'Group Master', this unit determines the group's operation. In the first group, G0, the group master is referred to as ID0. This unit is the overall master of the entire system. There can only be one unit with ID0 in the system.

Adding another group to the system means that one of the units in this group must be the 'Group Master'. The group master can be any of the units in the group.

All units must be programmed with their group identity (Group ID) as well as their own identity (Communication ID). This also applies to group control panels.

Example:

There are two units installed in a room. One of these units is the master; this unit is ID0. The other unit is ID1. They are both in the same group, i.e., group number 0. The system would look like this:

Group ID	Communication ID	
G0	ID0	Master
G0	ID1	Slave

Table 6: Group 0 example

Adding another group and more units:

Group ID	Communication ID	
G1	ID2	Group Master
G1	ID3	Slave
G1	ID4	Slave
G1	ID5	Slave

Table 7: Group 1 example

The system now consists of two groups and six units in total:

Group ID	Communication ID	
G0	ID0	Master
G0	ID1	Slave
G1	ID2	Group Master
G1	ID3	Slave
G1	ID4	Slave
G1	ID5	Slave


Table 8: System example

The system control panel must always be an Airlinq® Orbit panel. This panel is always connected to the Master (ID0). *Airlinq® Orbit panels are pre-programmed to ID179 as their Communication ID. This setting must not be changed.*

Group control panels (Airlinq® Viva panels) must follow the pairing table below:

Group ID	Communication ID
G0	ID160
G1	ID161
G2	ID162
...	...
G17	ID177
G18	ID178

Table 9: Group control panel pairing table

	<b>NOTICE</b>
	All programming is done via the 'Airlinq Service Tool' program directly on the units control box or the units control panel.

Unit programming must be done in a specific order:

1. Units ID1 to ID19, including any group control panels. See section 5.4.1 and 5.4.2.
2. Unit ID0. See section 5.4.3

We highly recommend that you create a system overview (see example in Table 8) before you do any programming. Decide which unit is the overall master, which units are group masters, and where any group control panel is connected. This will help you program the system correctly.

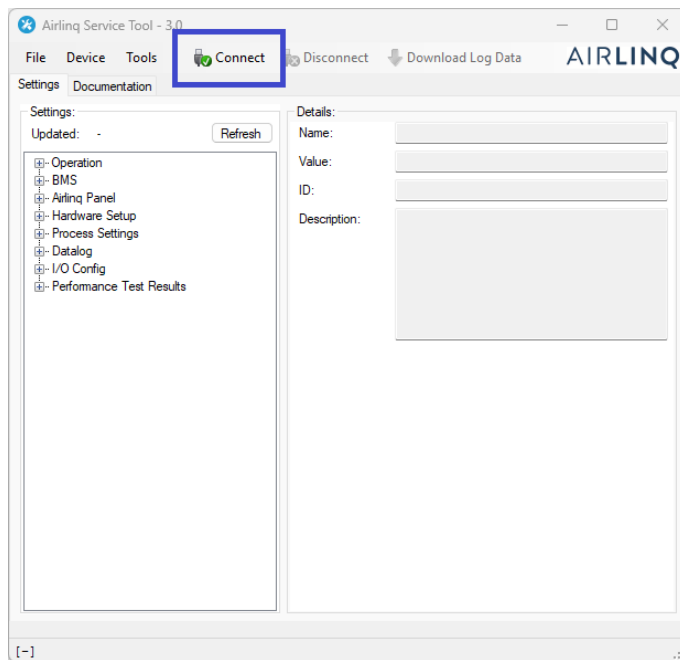
The system can be put into operation once all programming has been completed.

## 5.4.1 Units ID1 to ID19

Each unit is first provided with a Group ID, then its Communication ID. Once done, the unit is restarted, and you continue with the next unit.

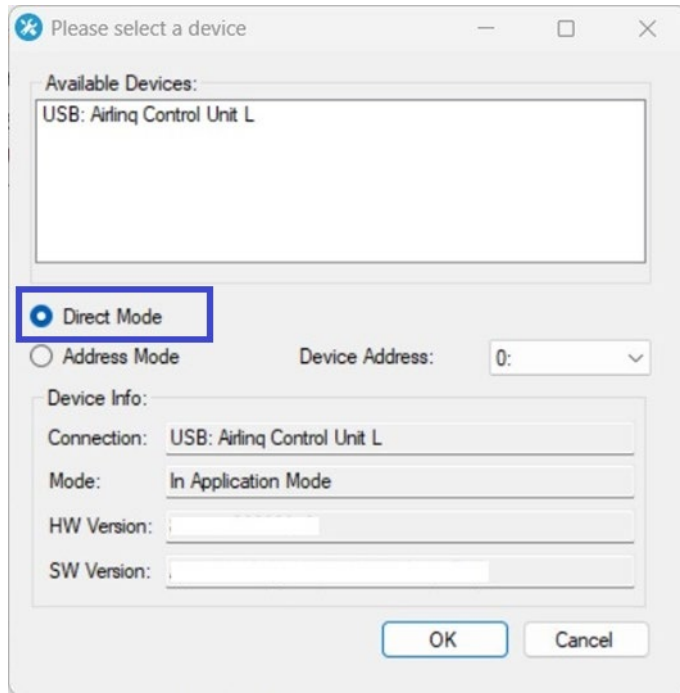
Start with unit ID1 and work your way through the system systematically.

1. Switch off the power supply.
2. Open the unit and connect a USB-cable to the mini-B USB port on the control box.
3. Switch the power on and wait for 30 seconds.
4. Connect a PC via the USB-cable. Start the 'Airlinq Service Tool'.
5. Click on "Connect".



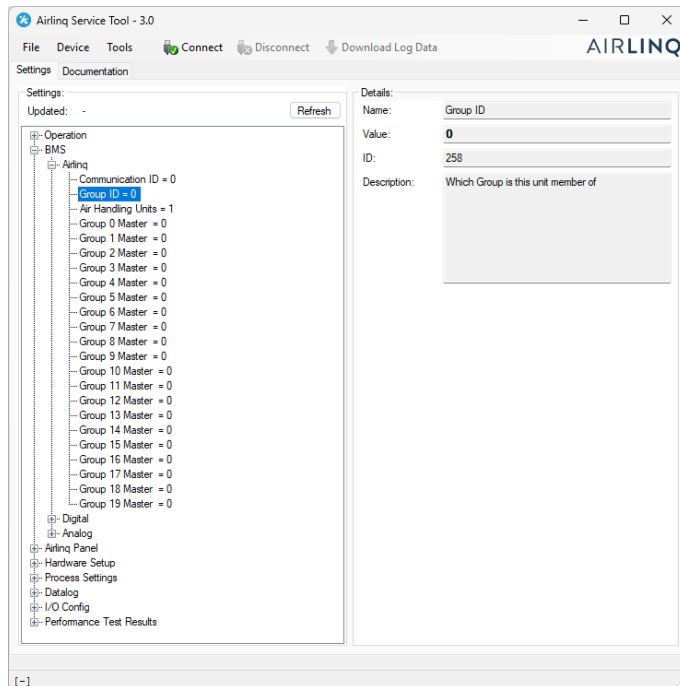
The "Please select your device" window opens.

6. Select "Direct Mode" and click "OK".



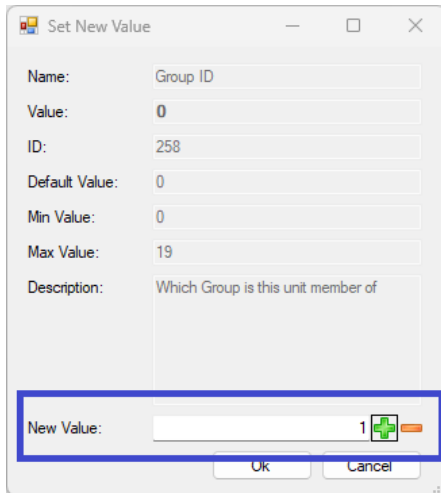
The program is now connected to the unit's control box. The "Please select your device" window closes.

7. Select "BMS" / "Airlinq" / "Group ID = 0" in the tree structure and press "Enter" on your PC.



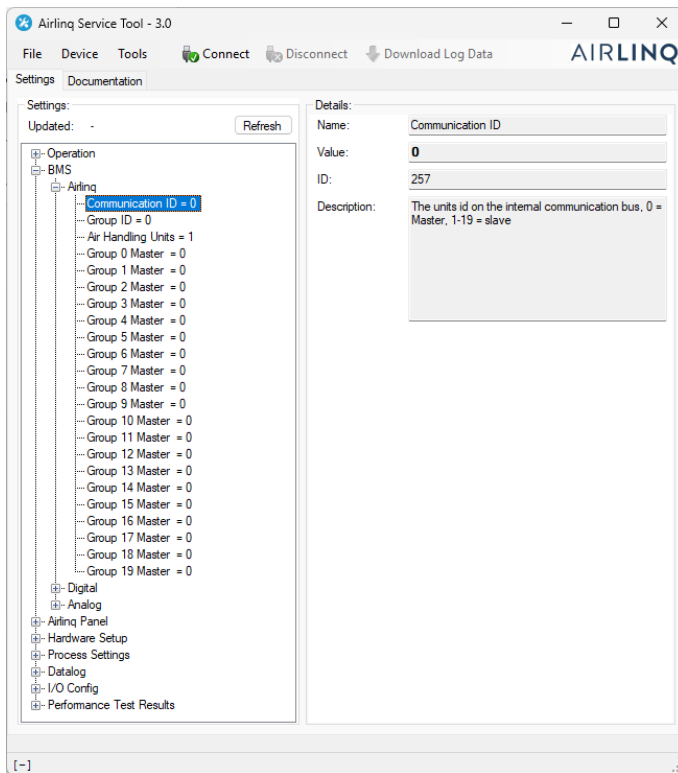
The "Set new value" window opens.

8. Enter the units group number, e.g., "1".



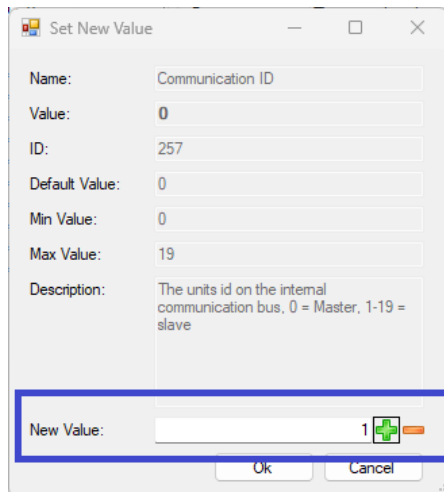
9. Click "OK". The "Set new value" window closes.

10. Select "BMS" / "Airlinq" / "Communication ID = 0" and press "Enter" on your PC.



The "Set new value" window opens.

11. Enter the units' Communication ID, e.g., "1".



12. Click "OK". The "Set new value" window closes, and the "Please re-connect" window opens.



13. Click "OK". The control box will restart. The "Please re-connect" window closes.
14. Reconnect to check that the new value is valid.
15. Switch off the power supply.
16. Remove the USB-cable from the control box.
17. Close the unit.
18. Switch the power on.

Repeat the procedure for the rest of the units (ID2, ID3, ID4, ...ID19) in numerical order.

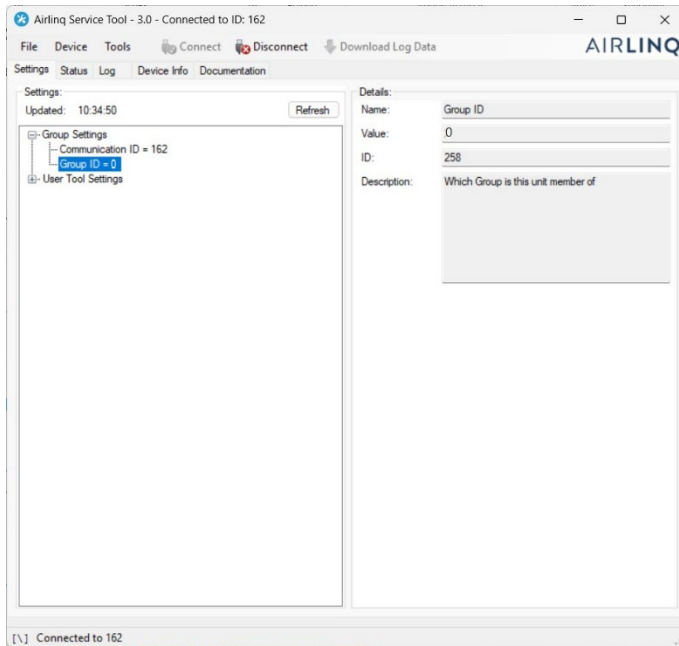
## 5.4.2 Group control panels for groups 1 to 19

If you have any group control panels in your system, these must also be assigned a Group ID and a Communication ID just as the units. It is, however, very important that you follow the numbering listed in Table 9 when it comes to Communication IDs.

Begin with group 1.

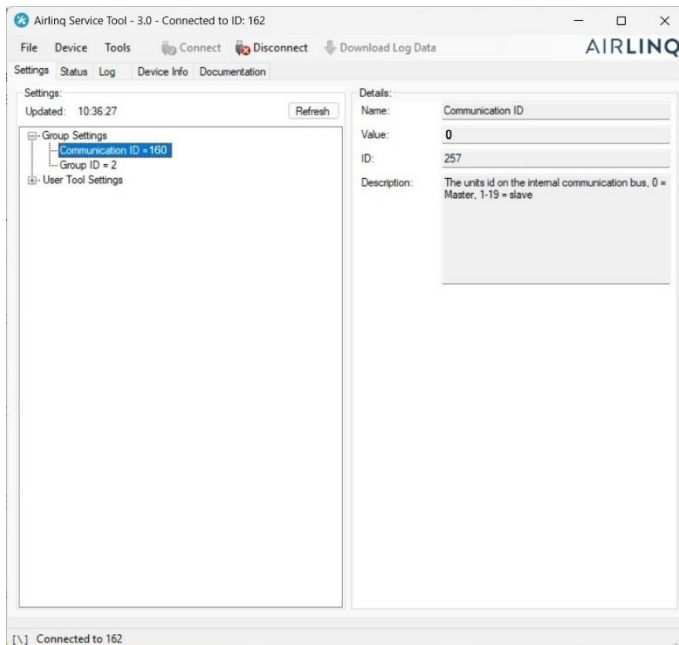
1. Connect a USB-cable to the mini-B USB port on the group control panel.
2. Connect a PC via the USB-cable. Start the 'Airlinq Service Tool'.
3. Repeat steps 5-6 in section 5.4.1. The program is now connected to the control panel. The "Please select your device" window closes.

4. Select "Group Settings" / "Group ID = 0" in the tree structure and press "Enter" on your PC



The "Set new value" window opens.

5. Enter the number of the group where the control panel is connected.
6. Click "OK". The "Set new value" window closes.
7. Select "Group Settings" / "Communication ID = 160" and press "Enter" on your PC



The "Set new value" window opens.

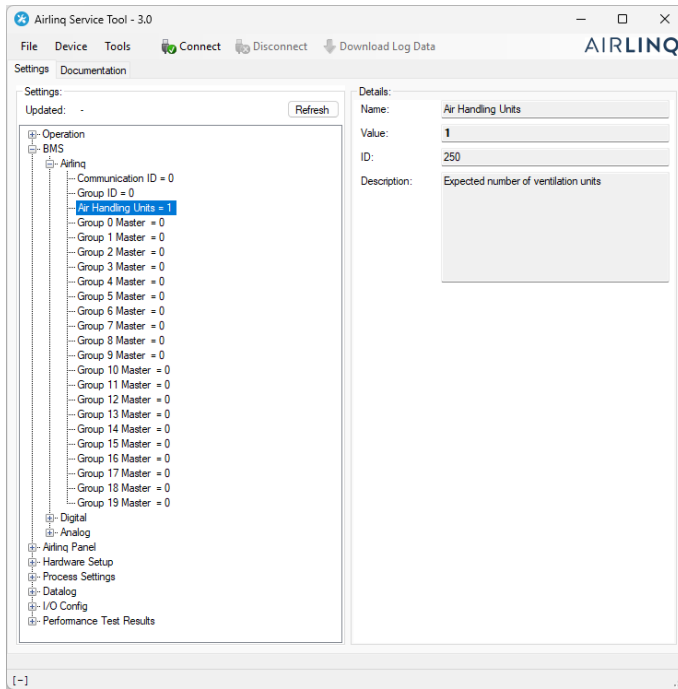
8. Enter the ID number from Table 9, e.g., "161" for the panel in group 1.
9. Click "OK". The "Set new value" window closes, and the "Please re-connect" window opens.
10. Press "Enter" on your PC. The control panel restarts, and the "Please re-connect" window closes.
11. Remove the cable from the control panel.

Repeat the procedure for any remaining group control panels (ID162, ID163, ID164, ... ID178).

### 5.4.3 Unit ID0

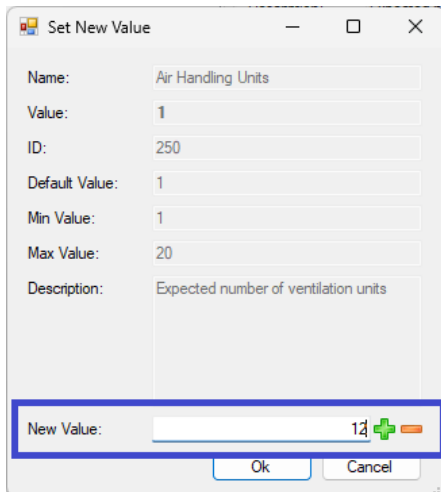
Unit ID0 is the overall master of the entire system. This unit must be programmed with information on how many units the system contains, as well as information on any group masters.

1. Repeat steps 1-6 in section 5.4.1.
2. Select "BMS" / "Airlinq" / "Air Handling Units = 1" in the tree structure and press "Enter" on your PC.



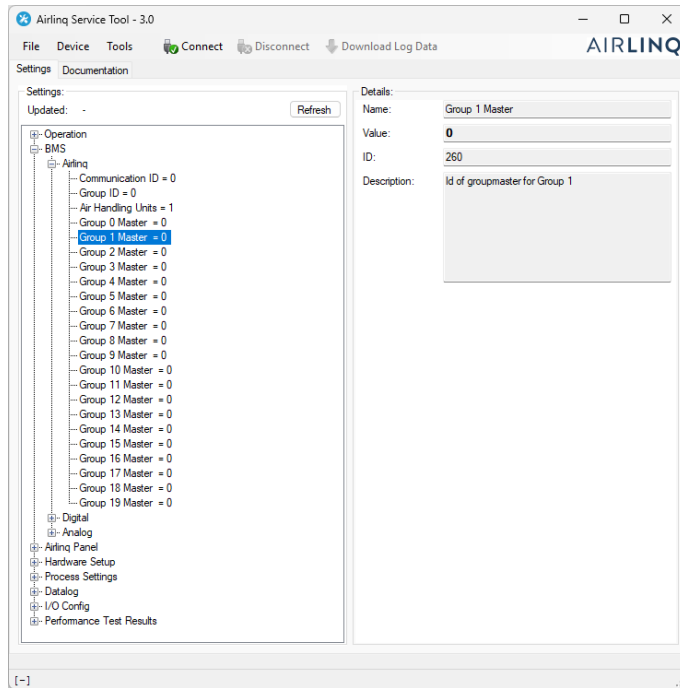
The "Set new value" window opens.

3. Enter the number of units in the system, e.g., "12" for a total of 12 units.



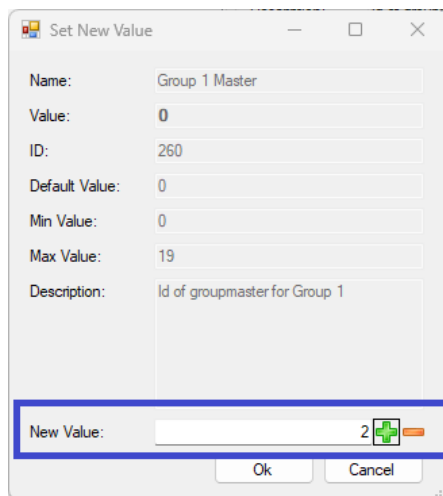
4. Click "OK". The "Set new value" window closes.

5. Select "BMS" / "Airlinq" / "Group 1 Master = 0" in the tree structure and press "Enter" on your PC.



The "Set new value" window opens.

6. Enter the Communication ID of the group master in Group 1, e.g. "2".



7. Click "OK". The "Set new value" window closes.  
All units in Group 1 will now be controlled by the group master; in the example above, the unit with Communication ID 2.
8. Repeat steps 5-7 for all groups in the system until all your group masters have been programmed. ("Group 0 Master = 0", "Group 1 Master = 0", "Group 2 Master = 0", "Group 19 Master = 0" in the tree structure). (Group Master in group 0 is usually ID0).
9. Repeat steps 15-18 in section 5.4.1.

This concludes the system programming.

## 6 Network connections

### 6.1 Ethernet connection (for Airlinq® Online)

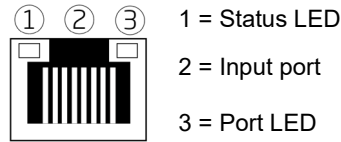


Figure 42: Ethernet, RJ45

#### 6.1.1 Test

The status LED is orange when the unit is connected to the power supply. When the module is connected to a local network, the port LED is green.

#### 6.1.2 Identification

Each network module has a unique MAC address on delivery. The MAC address is located on a label delivered with the module/glued onto the control box in the unit. For example:



Figure 43: MAC address

The unit's serial number is transferred to the network module. The Ethernet card should be connected to a switch/hub with a patch cable to establish a connection to Airlinq® Online. Once this is done, you can communicate with the unit via Airlinq® Online.

#### 6.1.3 Cable recommendation

We recommend using a CAT 5e STP (Shielded Twisted Pair) data cable with an RJ45 connector. The maximum recommended cable length is 70 meters.

#### 6.1.4 Unit connections, AQC-L

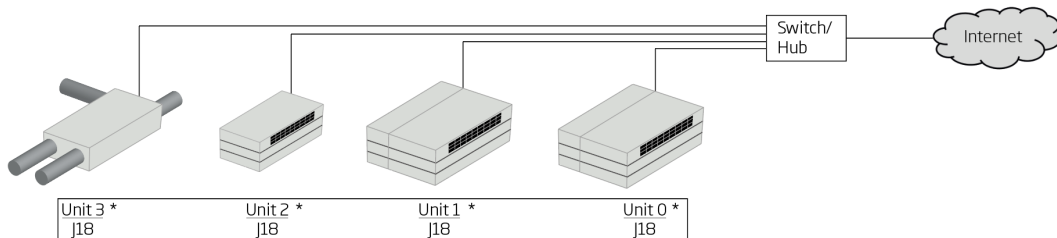


Figure 44: Ethernet, unit connections, AQC-L

### 6.1.5 Unit connections, AQC-P

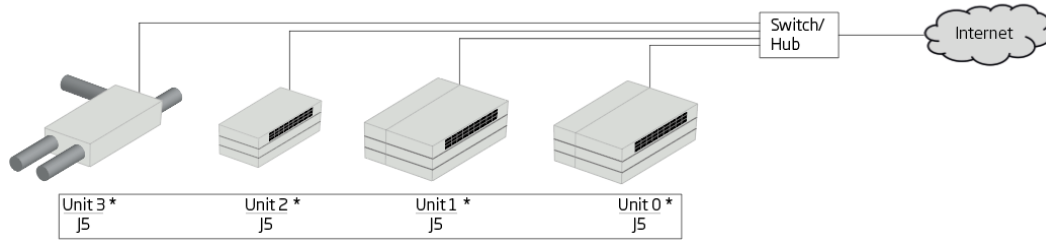


Figure 45: Ethernet, unit connections, AQC-P

### 6.1.6 Airlinq BMS + Airlinq® Online

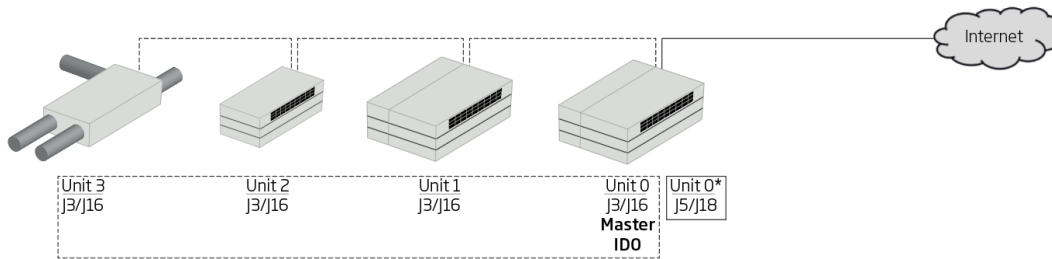


Figure 46: Airlinq BMS and Airlinq® Online, unit connections

## 6.2 MODBUS® RTU RS485

MODBUS® plug	Pin 1	Signal common/GND
	Pin 2	Bus-B input
	Pin 3	Bus-B output
	Pin 4	Bus-A input
	Pin 5	Bus-A output
D9	MODBUS® communication, yellow LED	
D8	MODBUS® error, red LED	

Table 10: MODBUS®

DIP switch:

SW1	“On” for the first and last unit in the chain. “Off” for all other units.
SW2/3	“On” when the bus requires “failsafe biasing”, or “Off”

Table 11: DIP switch settings

### 6.2.1 Test

LED D8 signals a fault (flashes red) until the module is programmed.

### 6.2.2 Addressing

Register	Parameter	Designation	Value
40001	ID402	Modbus Address	3
40002	ID403	Modbus Baud Rate	19200
40003	ID404	Modbus Parity	Even (1 Stop bit)

Table 12: MODBUS® addressing

Addressing can be performed using the ‘Airlinq Service Tool’ or directly via the network.

DIP switches SW1, SW2, and SW3 must be set in compliance with the system’s standard and installation.

### 6.2.3 Cable recommendation

Shielded Twisted Pair (STP) data cable (2+1 or 2x2) according to “Modbus Serial Line Protocol and Implementation Guide V1.02”. See [www.modbus.org](http://www.modbus.org).

An AWG 24 STP data cable (2+1 or 2x2) is usually adequate for MODBUS® data communication. The shield is placed on the frame, see Figure 47.

## 6.2.4 Unit connections, AQC-L

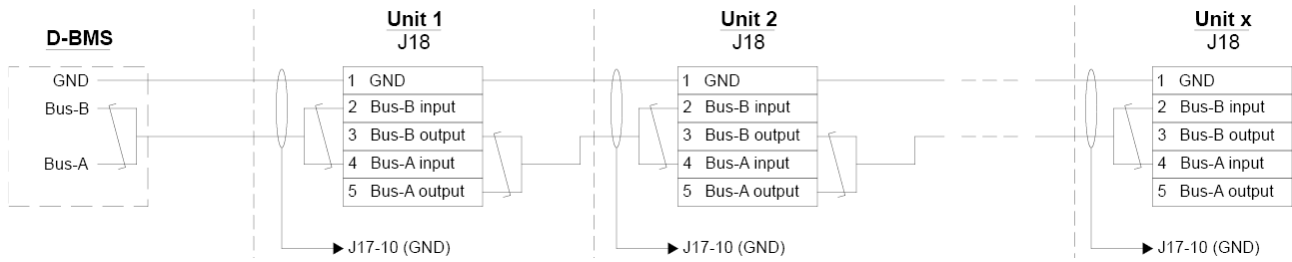


Figure 47: MODBUS<sup>®</sup>, unit connections, AQC-L

## 6.2.5 Unit connections, AQC-P

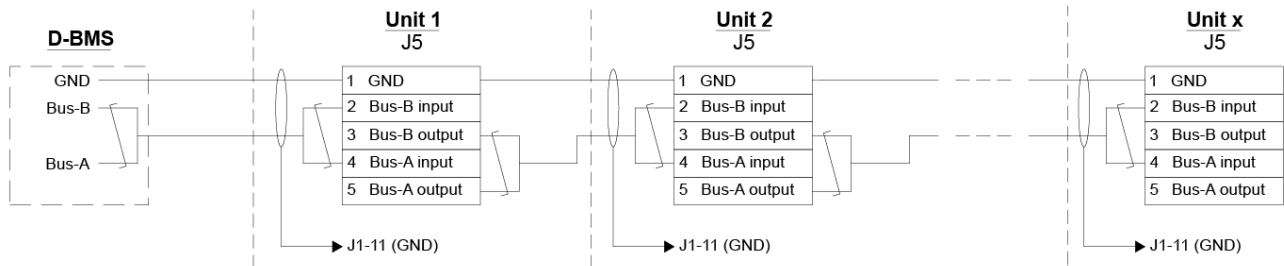
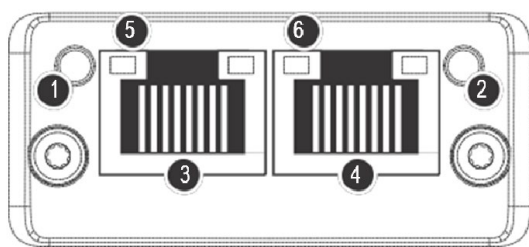


Figure 48: MODBUS<sup>®</sup>, unit connections, AQC-P

## 6.3 BACnet™/IP



- 1 = Network status LED (NS)
- 2 = Module status LED (MS)
- 3 = Input
- 4 = Output
- 5 = Link/Activity Port 1
- 6 = Link/Activity Port 2

Figure 49: BACnet™ /IP

### 6.3.1 Test

Check that the module status LED (2) has a green light. You can also use a PC connected directly to the network module to scan the network. To do this, you can use the IP configuration tool program available on Airmaster's website.

### 6.3.2 Identification

Each network module has a unique Unit ID. The ID number is located on a label delivered with the module/glued onto the control box in the unit. For example:

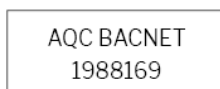


Figure 50: Network module ID example

Use the 'Airlinq Service Tool' to read the ID number, which is displayed in the 'Status' window.

### 6.3.3 Cable recommendation

At least one AWG 24 CAT 5e STP (Shielded Twisted Pair) data cable with RJ45 connector.

The maximum recommended length for an IP segment with AWG 24 cables is 70 meters.

### 6.3.4 Unit connections, AQC-L

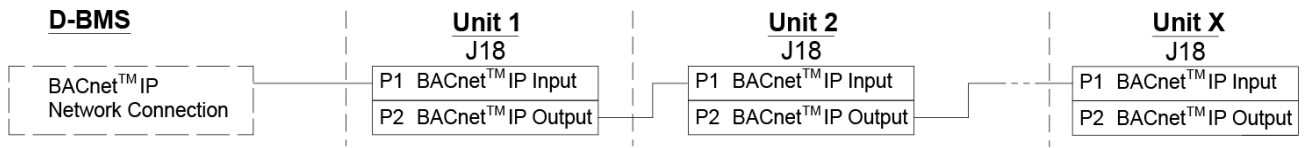


Figure 51: BACnet™ IP, unit connections, AQC-L

### 6.3.5 Unit connections, AQC-P

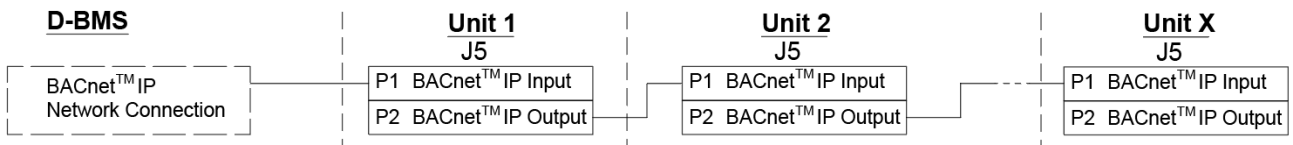


Figure 52: BACnet™ IP, unit connections, AQC-P

## 6.4 BACnet™ MS/TP

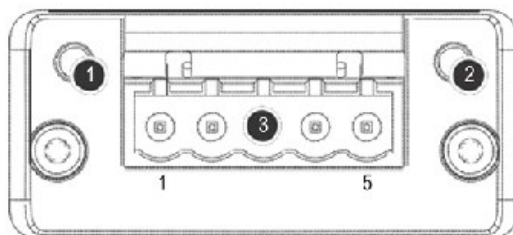


Figure 53: BACnet™ MS/TP

1		Network status LED (NS)	
2		Module status LED (MS)	
3	BACnet™ plug	Pin 1	Signal common/GND
		Pin 2	Data - / Bus-B
		Pin 3	Shield
		Pin 4	Data + /Bus-A
		Pin 5	-

Table 13: BACnet™

### 6.4.1 Test

Check that the module status LED (2) has a green light.

### 6.4.2 Addressing

Index	Parameter	Name	Value
128	ID405	BACnet MS/TP Address	0
129	ID406	BACnet MS/TP Baud Rate	9600

Table 14: BACnet™ MS/TP

Addressing can be performed using the 'Airlinq Service Tool' or directly via the network.

### 6.4.3 Cable recommendation

Shielded Twisted Pair (STP) data cable (2+1 or 2x2) according to "ANSI/ASHRAE Addendum to ANSI/ASHRAE Standard 135-2008".

- Characteristic impedance between 100 and 130 ohms.
- Capacitance between the wires must be less than 100 pF per meter.

The maximum recommended length in an MS/TP segment with an AWG 18 cable is 1200 m. The shield is placed on the frame, see Figure 54.

### 6.4.4 Unit connections, AQC-L

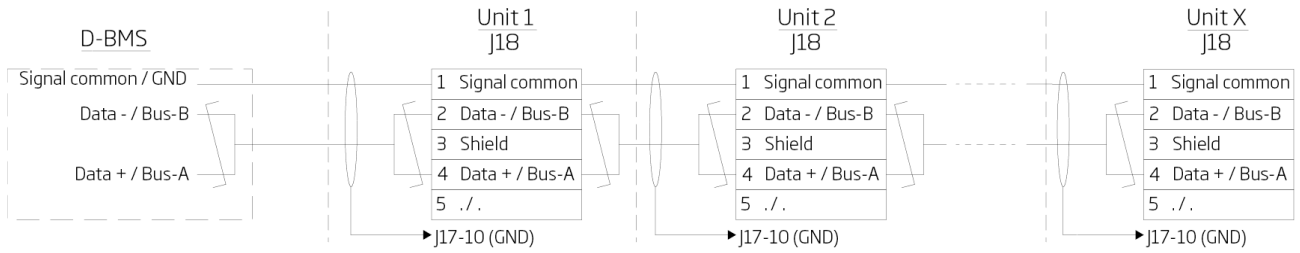


Figure 54: BACnet™ MS/TP, unit connections, AQC-L

### 6.4.5 Unit connections, AQC-P

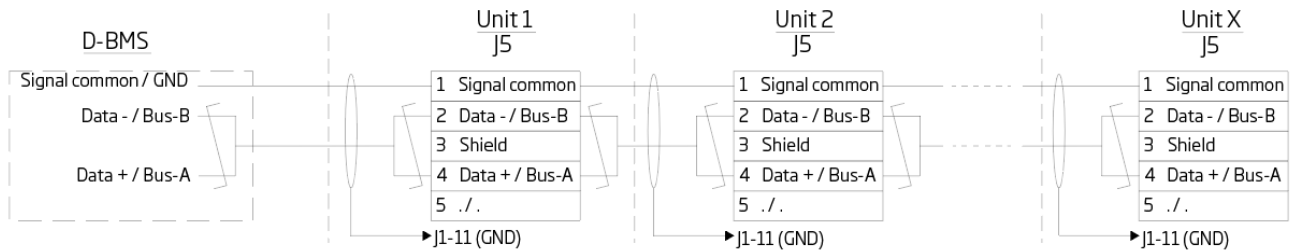


Figure 55: BACnet™ MS/TP, unit connections, AQC-P

## 7 Commissioning

When the mounting and installation of the unit is complete, the basic operating functions must be checked.

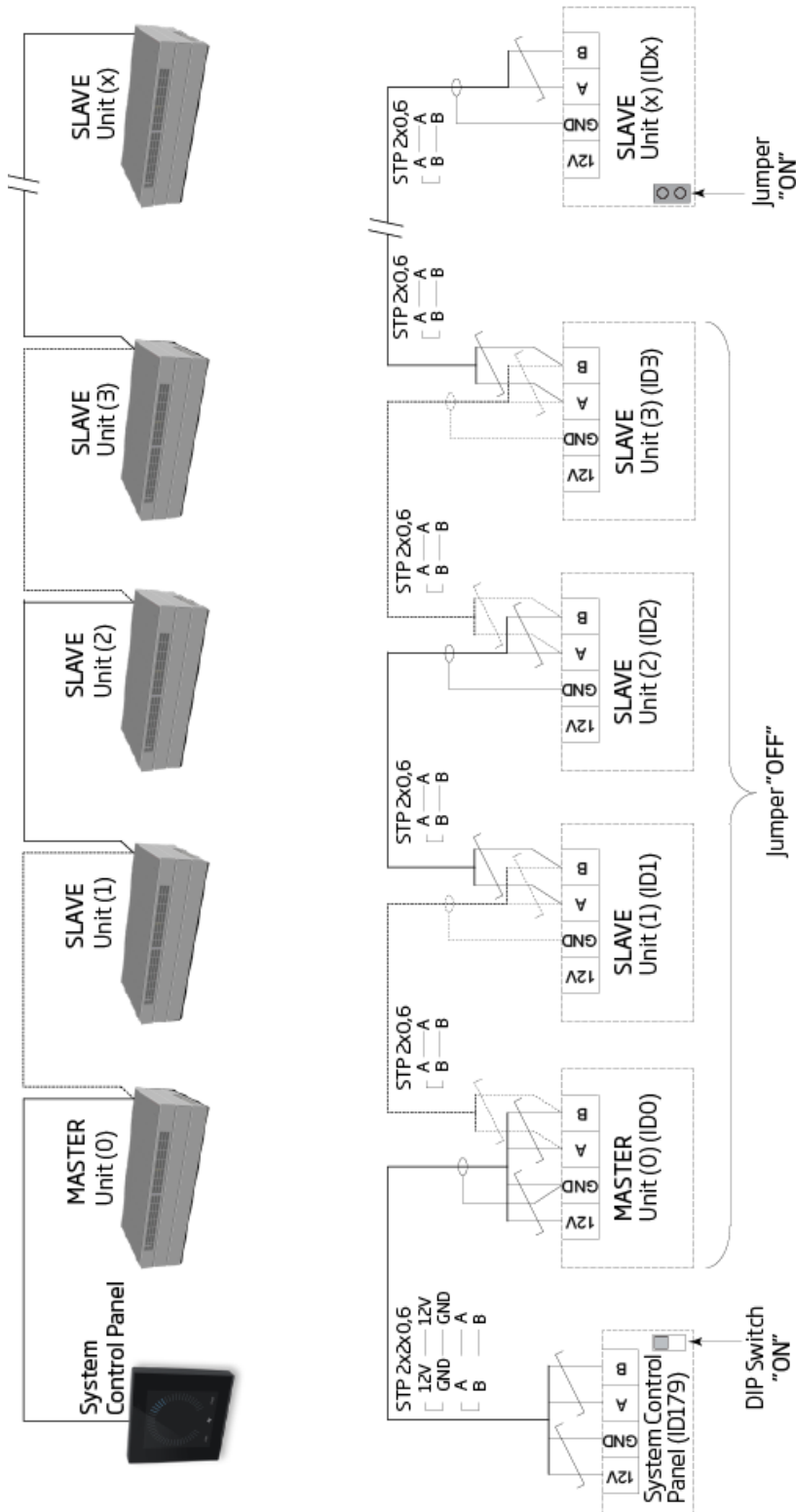
With Airlinq BMS systems, general settings can be made for the whole system or groups. However, unit-specific settings must be set on each unit individually, using the 'Airlinq Service Tool'.

- Close the unit.
- Switch the power supply on.
- For units with Airlinq® Orbit control panel:  
The control panel's "Startup Guide" will automatically start when the unit is started for the first time. It can also be activated manually from the "Settings - Startup Guide" menu item. Further details are available in the "Operation and Maintenance" manual supplied with the unit. Follow the instructions in the Startup Guide closely, finishing with the startup of the unit.
- Check that the extract air and inlet air draw and blow, respectively.
- Perform other settings using a PC running the 'Airlinq Service Tool'. Enter all data required by the "Operation and Maintenance" manual and the instructions in the program.
- Once the settings have been made stop the unit temporarily.
- Restart the unit.
- Check the inlet flow pattern in the room at max. airflow. Adjust the inlet flow pattern according to the guide in the "Operation and Maintenance" manual if necessary.
- Optionally complete the "Performance Test" using a PC running the program 'Airlinq Service Tool'

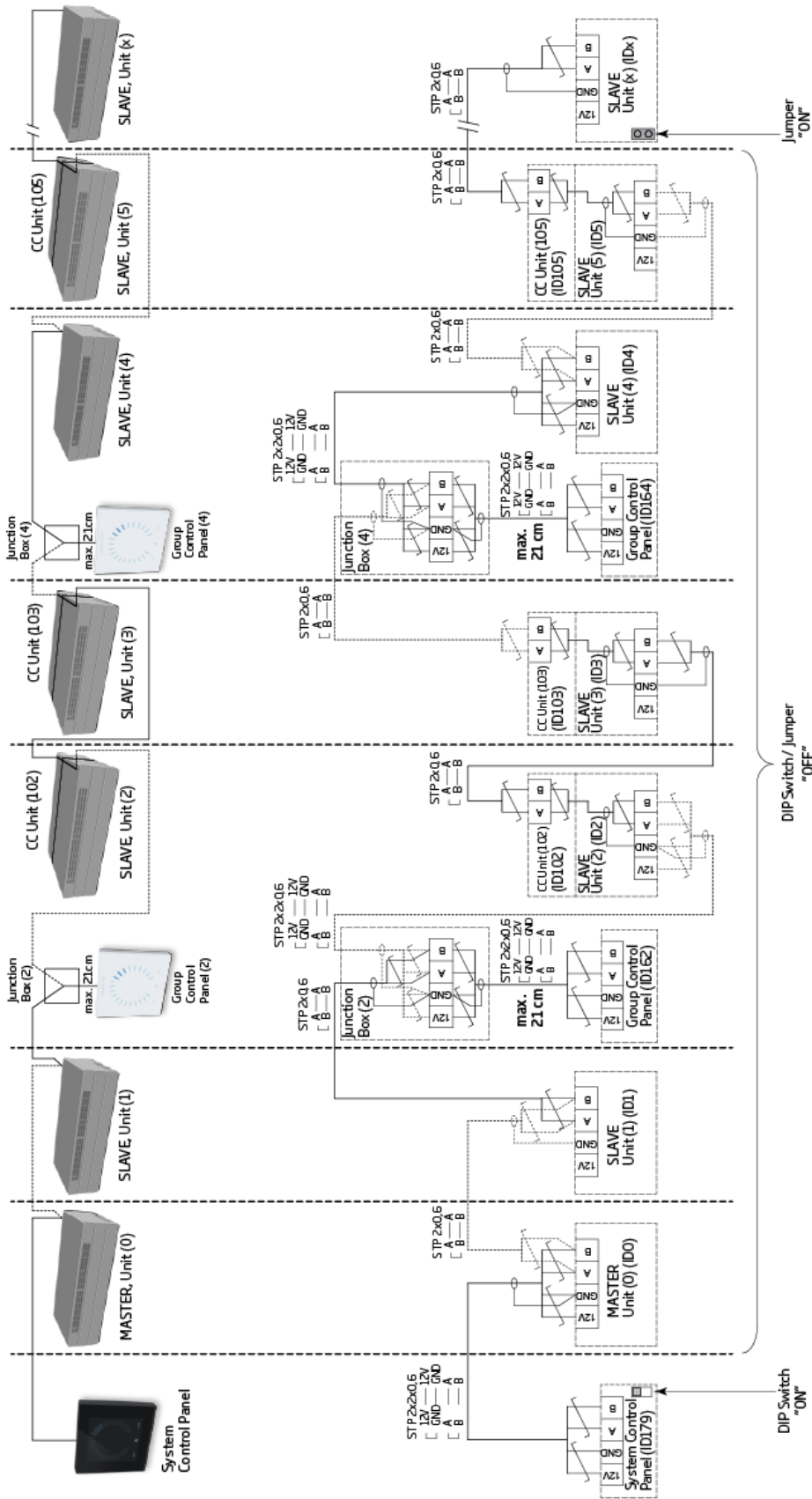
Filter calibration will automatically be performed after 25 hours of operation if this is not done during commissioning.

# Appendix A Wiring diagrams for typical Ailing BMS systems

## Individual units, one system control panel



# Combined system



## Appendix B Error descriptions

Start-up problems may be due to a simple installation error. Please look through the error descriptions below to ensure that the installation has been carried out correctly.

**Error: The Airlinq® Orbit control panel's air indicator is moving from one side to the other.**

Cause: The data connection from the control panel to the unit was disconnected.

**Error: None of the equipment with a 12-volt supply is functioning.**

Cause: The leads to "0-10 V" and "GND" are the wrong way around.

### **Airlinq BMS:**

**Error: The Airlinq® Orbit control panel shows random warnings and/or alarms.**

Cause: The data connection cable is connected to 12V, GND, A, and B for all units. The connection must be corrected.

**Error: One or more of the units in the system cannot be seen on the communication bus with the 'Airlinq Service Tool', Airlinq User Tool program, or on the Airlinq® Orbit control panel.**

Cause:

- Some units are not connected to the power supply.
- Data communication cables (A and B) are connected the wrong way.
- Data connection to individual units is disconnected or not installed correctly.
- Communication ID or group ID for some units is programmed incorrectly.
- Jumper/switches are not set correctly.

**Error: The Airlinq® Orbit control panel is reporting an error.**

Cause: Short circuit in the data communication between A and B.

**Error: The Airlinq® Orbit control panel is not working (no light in the panel).**

Cause:

- 12 V and GND have been connected the wrong way.
- 12 V and/or GND not connected or disconnected.

**Error: The Airlinq® Orbit control panel is not working (no light in the panel) or no data communication on the bus.**

Cause: GND to the control panel is not connected or is disconnected.

**Error: Unit stopped due to a condensate alarm, although there is no condensation in the condensate tray, and the Airlinq® Orbit control panel is not working (no light in the panel).**

Cause: Short circuit between 12 V and GND.

**Error: Group settings cannot be seen on one or more of the units with communication IDs ID1, ID2, ... ID19.**

Cause:

- The data connection is disconnected or not installed.
- Data communication cables (A and B) are connected the wrong way around.
- Communication ID or group ID for some units is programmed incorrectly.
- Some units are not installed according to the Airlinq BMS chart.
- Jumper/switches for some units are not set correctly.

*This page is intentionally left blank*

# AIRMASTER

16104\_REV03.1\_2026-01-21

Errors and omissions excepted. Subject to change without notice. Original user instruction.