

Datasheet AM 1200 H



Technical data	Filter class	30 dB(A)	33 dB(A)	35 dB(A)
Maximum capacity ¹	ePM ₁₀ 50%	930 m ³ /h	1055 m ³ /h	1180 m ³ /h
Horizontal model, right/left:	ePM ₁ 55%	837 m ³ /h	950 m ³ /h	1062 m ³ /h
	ePM ₁ 80%	744 m ³ /h	844 m ³ /h	944 m ³ /h
Maximum capacity ¹	ePM ₁₀ 50%	1050 m ³ /h	1180 m ³ /h	1310 m ³ /h
Horizontal model, center:	ePM ₁ 55%	945 m ³ /h	1062 m ³ /h	1179 m ³ /h
	ePM ₁ 80%	840 m ³ /h	944 m ³ /h	1048 m ³ /h
Throw length (0.2 m/s) ¹ - right/left	min.			4 m v. 1000 m ³ /h
	max.			9 m v. 1000 m ³ /h
Throw length (0.2 m/s) ¹ - center:	min.			5.5 m v. 1300 m ³ /h
	max.			11 m v. 1300 m ³ /h
Supply air filter	ePM ₁₀ 50%, ePM ₁ 55% or ePM ₁ 80%			
Extract air filter	ePM ₁₀ 50%			
Dimensions (BxHxD)	Horizontal:	496 x 2098 x 2427 mm		
	Vertical:	496 x 2406 x 2427 mm		
Weight, including painted panels	Right-/left model:	545 kg		
	Center model:	630 kg		
Color casing	RAL 7024			
Counterflow heat exchanger	4 x Aluminum			
Air leakage classification cf. EN1886/EN13141-7	Class L2 / A2			
Air leakage classification main damper, cf. EN1751	Class 3			
IP code	10			
Duct connection	Ø400 mm			
Condensate pump (Capacity ; Lifting height at 5 l/h)	10 l/h ; 6 m			
Condensate drain hose int./ext. diameter	Ø4 mm / Ø6 mm			
Supply voltage	220-240V/50Hz, ~1N+PE			
	220-240V/50Hz, ~3N+PE			
Nominal power consumption ¹	254 W			
Nominal current ¹	1.4 A			
Power factor	0.6			
Maximum fuse	16 A (1 phase, type B)			
	3 x 16 A (3 phases, type B). When choosing a pre-heating surface, a 3-phase connection must be used			
Leakage current AC / DC	≤ 9 mA			
Recommended residual current breaker (RCCB)	Type B			

¹ All measurements were performed in normal operating mode in a standard installation using the facade grills Ø400 recommended by Airmaster.

² The supply can be limited to a single-phase, connected to L1. Only for air handling units without electric heating surface.

Electrical heating surfaces	Preheating surface	Comfort heating surface
Heat output	2500 W	1670 W
Nominal current	10.9 A	7.3 A
Thermal circuit breaker, manual reset	100 °C	100 °C

Water heating surface

Nominal heat output ³	2454 W
Connection dimension	1/2" (DN 15)
Materials pipes/fins	Copper/aluminum
Opening/closing time motor valve	60 s
Maximum operating temperature	90 °C
Maximum operating pressure	5 bar

³ Heat output for maximum capacity at 35 dB(A), delivery/return temperature 60/40°C and a liquid flow of 107 l/h.

AM 1200 H - R/L

Capacity with ePM₁₀ 50% / ePM₁₀ 50% filters ⁴

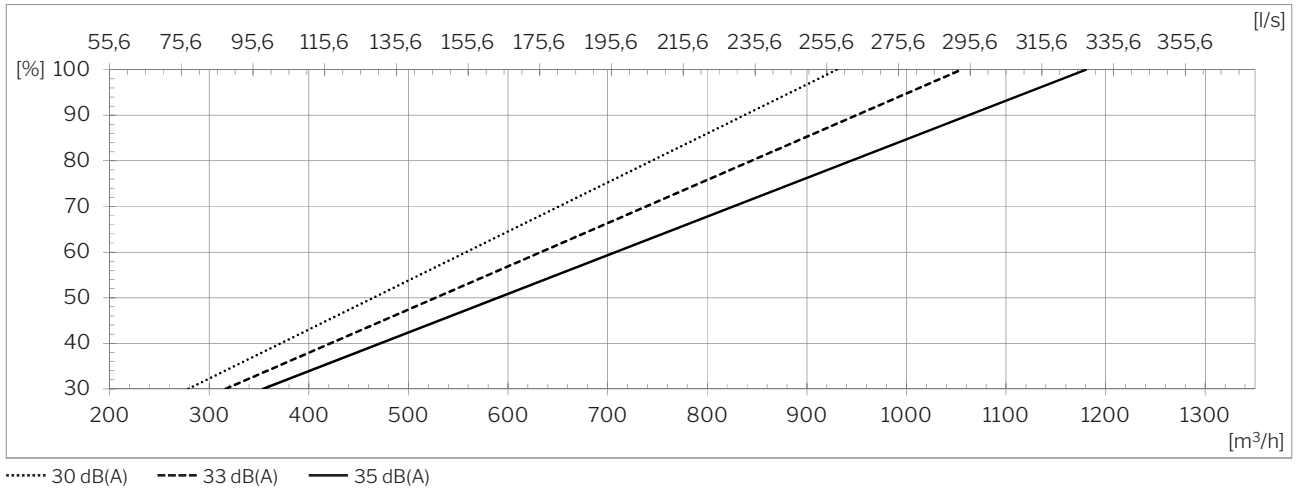

Capacity with ePM₁ 55% / ePM₁₀ 50% filters ⁴

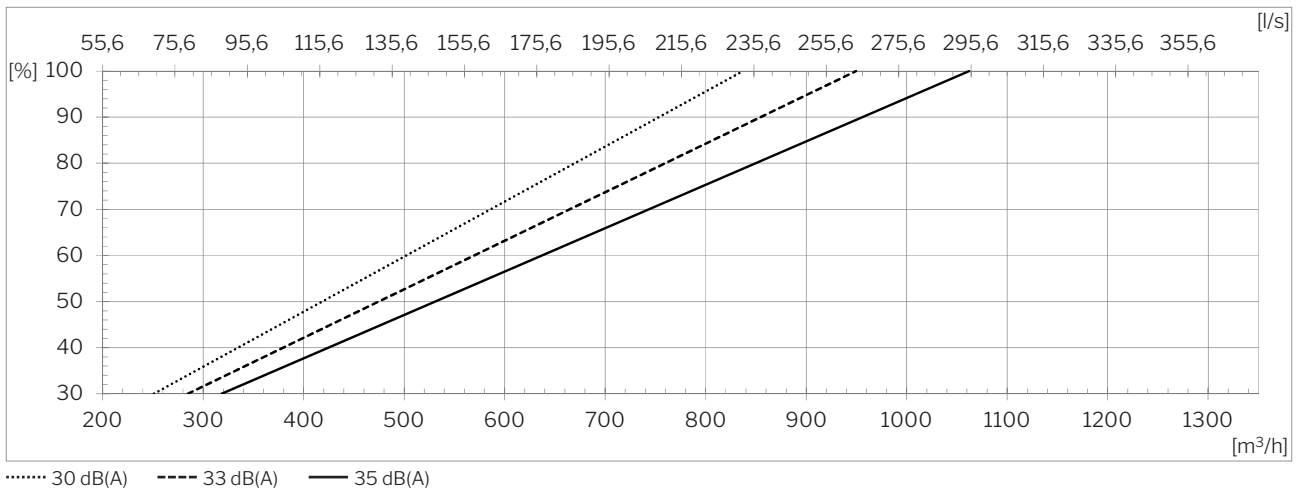

Capacity with ePM₁ 80% / ePM₁₀ 50% filters ⁴

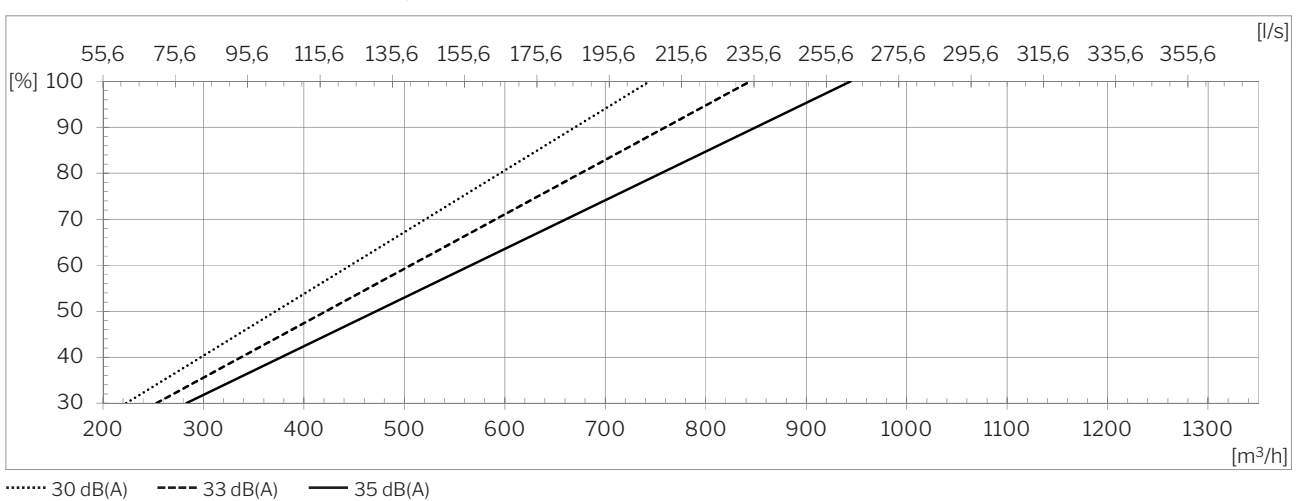

⁴ All measurements were performed in normal operating mode in a standard installation using the facade grills Ø400 recommended by Airmaster.

AM1200 H - C

Capacity with ePM₁₀ 50% / ePM₁₀ 50% filters ⁵

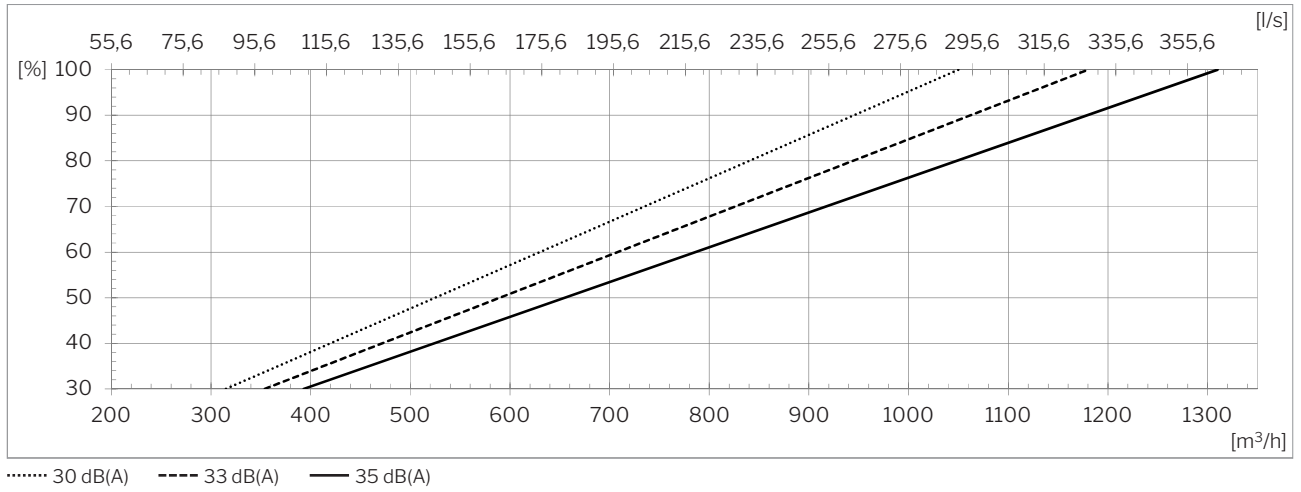

Capacity with ePM₁ 55% / ePM₁₀ 50% filters ⁵

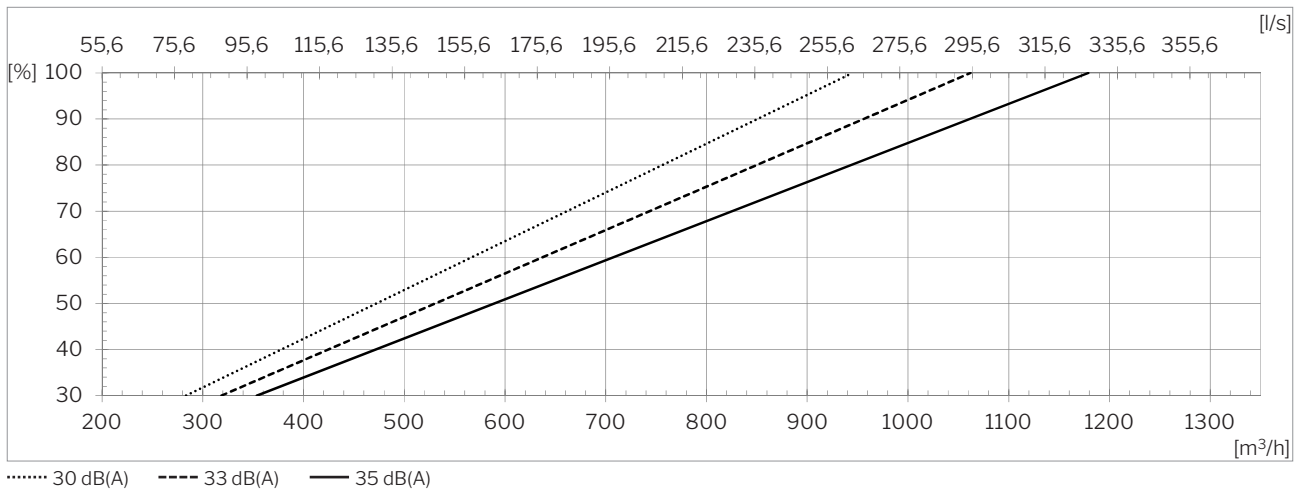

Capacity with ePM₁ 80% / ePM₁₀ 50% filters ⁵

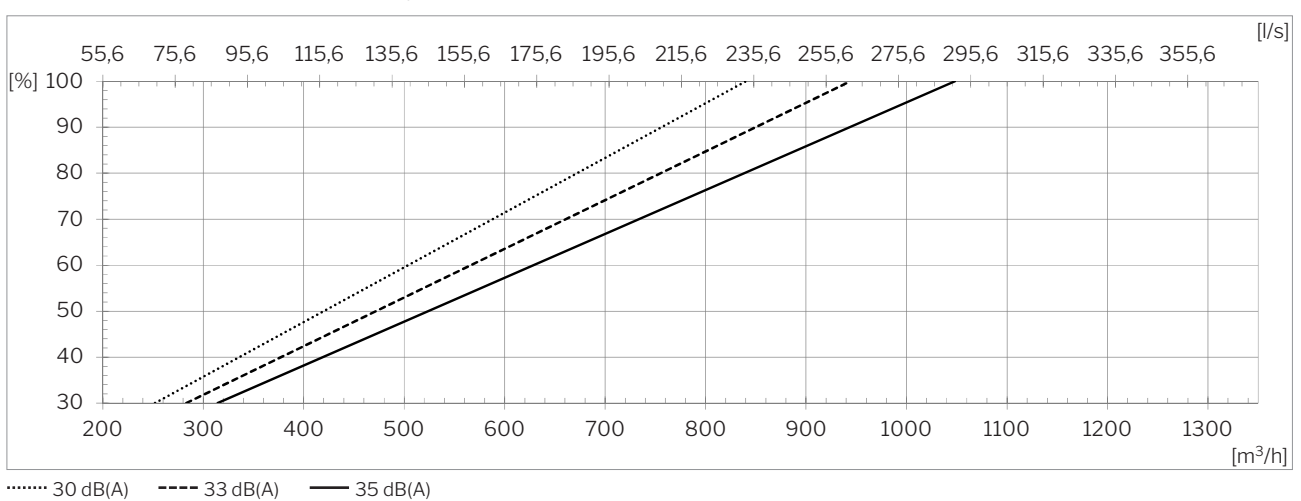

⁵ All measurements were performed in normal operating mode in a standard installation using the facade grills Ø400 recommended by Airmaster.

Sound pressure ⁶L_{pA,eq} acc. Airmaster reference situation

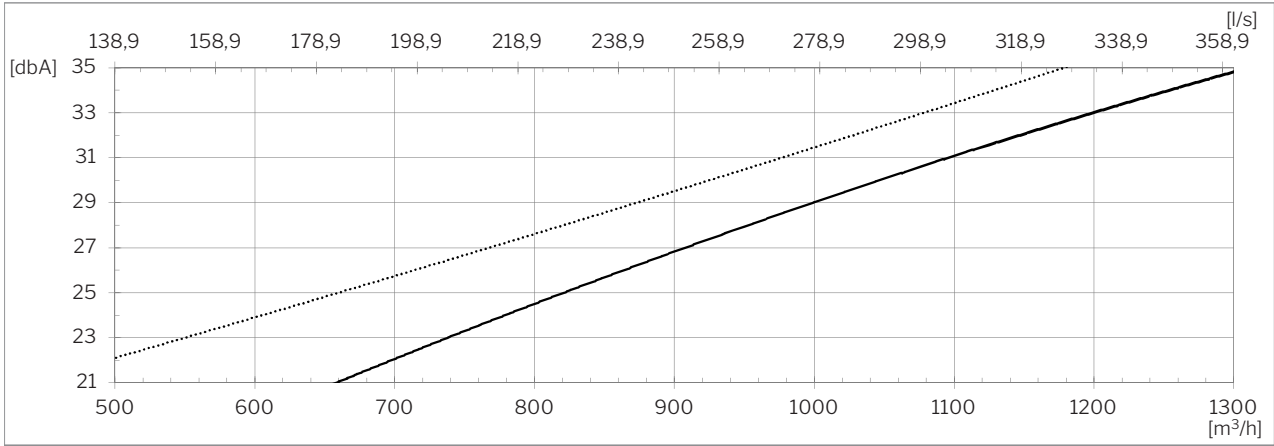

..... Right/left

— Center

Temperature efficiency acc. EN 308

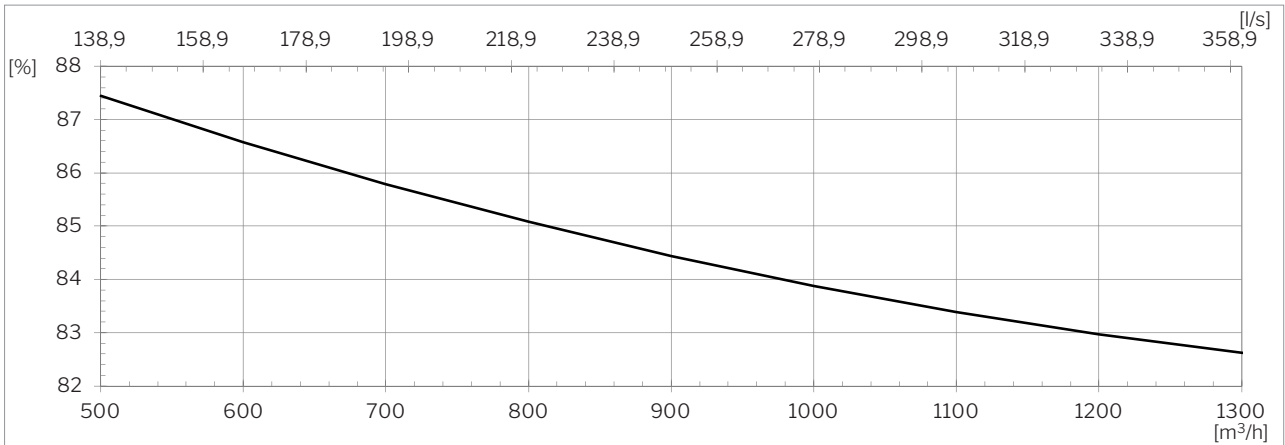

— Balanced airflow; Extraction: 25 °C, 28 % RH; Supply: 5 °C.

Power consumption ⁷

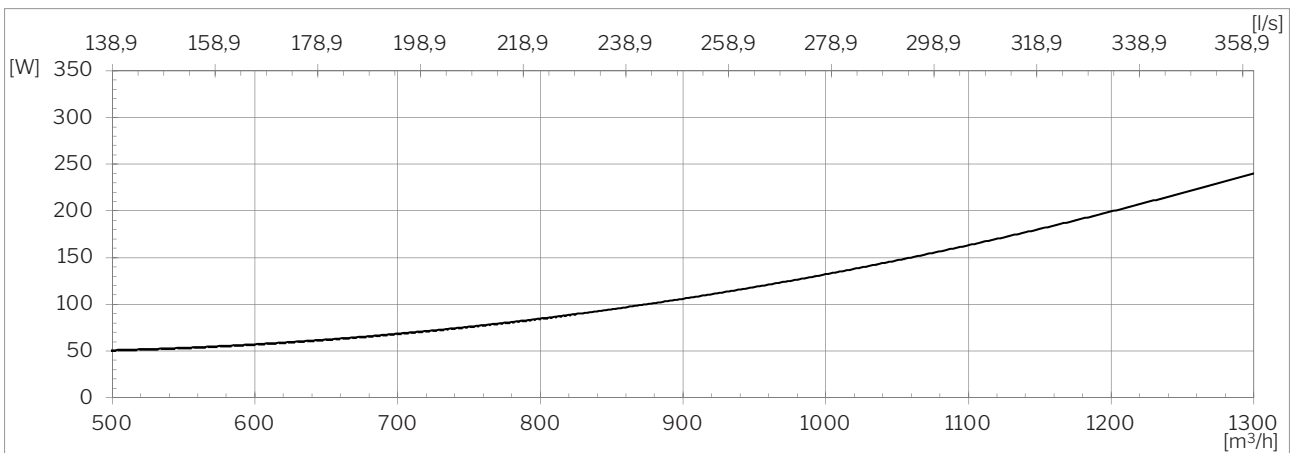

— ePM₁₀ 50% / ePM₁₀ 50%

⁶ Sound pressure level L_{pA,eq} is measured in a height of 1.2 m with at horizontal distance of 1 m from the air handling unit in room with a size of 200 m³ and a reverberation time of T = 0.6 s, corresponding to a room attenuation of 7.5 dB.

⁷ All measurements were performed in normal operating mode in a standard installation using the facade grills Ø400 recommended by Airmaster.

SFP⁸

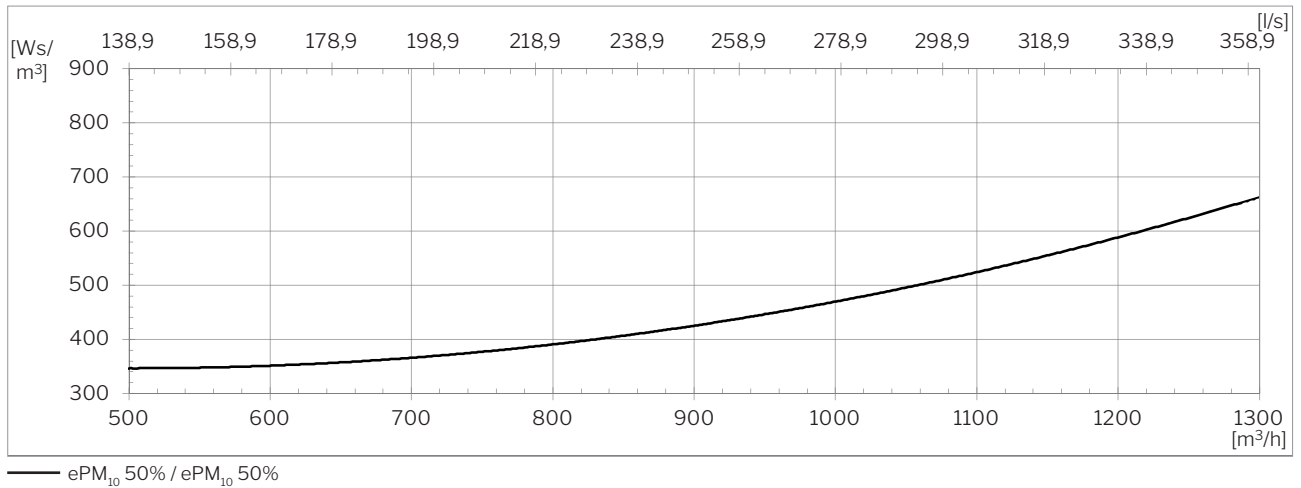

External pressure loss - Supply air⁸

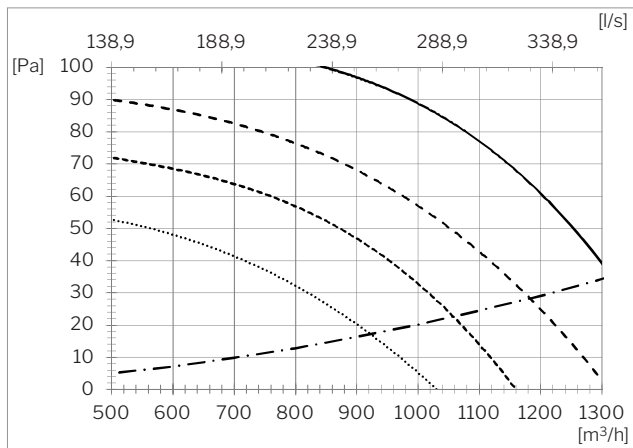

- Center, 35 dB(A), ePM10 50% filter
- - - - Right/left, 35 dB(A), ePM10 50% filter
- · - · - Center, 30 dB(A), ePM10 50% filter
- Right/left, 30 dB(A), ePM10 50% filter
- · - · - Recommended roof caps Ø400

External pressure loss - Extract air⁸

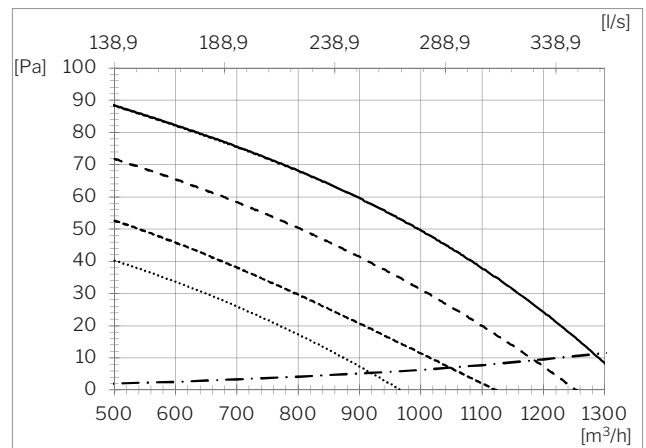

- Center, 35 dB(A), ePM10 50% filter
- - - - Right/left, 35 dB(A), ePM10 50% filter
- · - · - Center, 30 dB(A), ePM10 50% filter
- Right/left, 30 dB(A), ePM10 50% filter
- · - · - Recommended roof caps Ø400

⁸ All measurements were performed in normal operating mode in a standard installation using the facade grills Ø400 recommended by Airmaster.

Throw length (0.2 m/s)

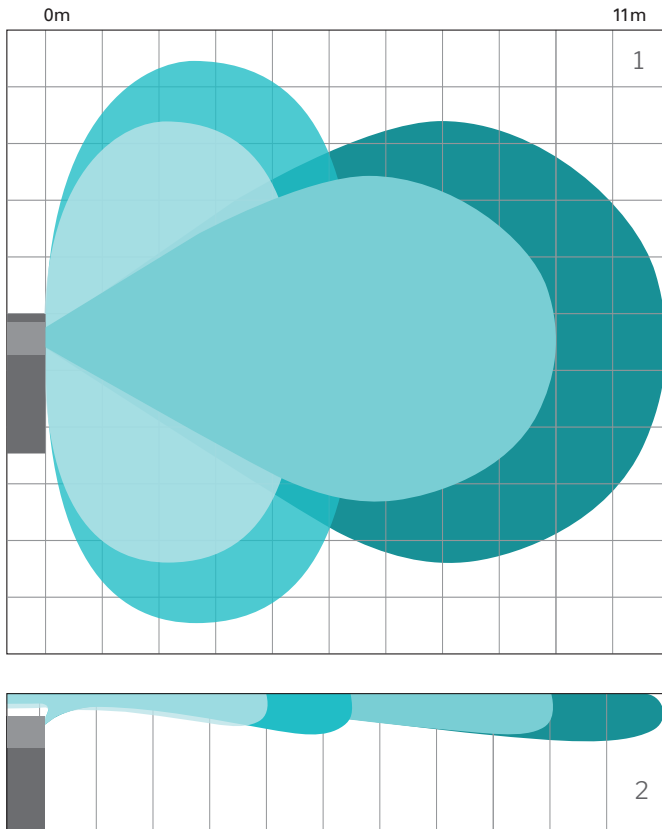

1300 m³/h

- Max.
- Min.

1000 m³/h

- Max.
- Min.

The AM 1200 unit spreads an air stream in different directions, depending on the given airflow.

This can be seen in the illustration, in which the blue shading indicates throw length the different airflows.

¹Throw length seen from above.

²Throw length seen from the side.

Variants

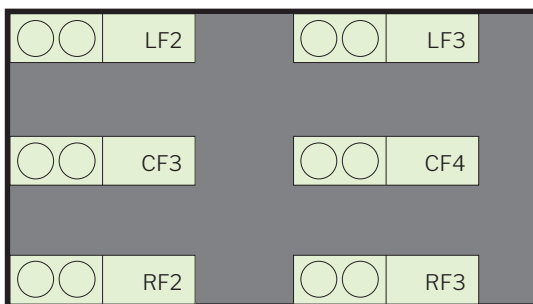

- AM 1200 VRF2 (right, with 2 open sides)
- AM 1200 VRF3 (right, with 3 open sides)
- AM 1200 VCF3 (centre, with 3 open sides)
- AM 1200 VCF4 (centre, with 4 open sides)
- AM 1200 VLF2 (left, with 2 open sides)
- AM 1200 VLF3 (left, with 3 open sides)

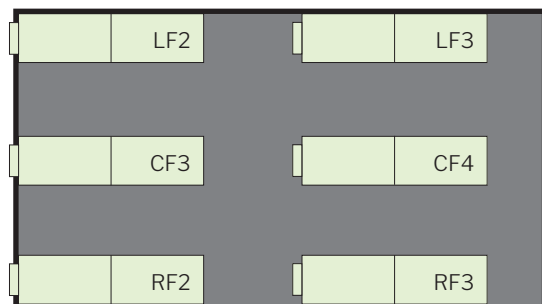

- AM 1200 HRF2 (right, with 2 open sides)
- AM 1200 HRF3 (right, with 3 open sides)
- AM 1200 HCF3 (centre, with 3 open sides)
- AM 1200 HCF4 (centre, with 4 open sides)
- AM 1200 HLF2 (left, with 2 open sides)
- AM 1200 HLF3 (left, with 3 open sides)

Standard and options

Counterflow heat exchanger (aluminum)	x	Energy meter	•
Enthalpy counterflow heat exchanger (Polymer membrane)	o	Supply air filter ePM ₁₀ 50%	•
Combination counterflow heat exchanger (Polymer membrane)	o	Supply air filter ePM ₁ 55%	•
Motor-driven bypass	x	Supply air filter ePM ₁ 80%	o
Sprint-return motor driven exhaust air damper	x	Extract air filter ePM ₁₀ 50%	x
Spring-return motor driven supply air damper	x	Airlinq Viva control panel	•
Electric preheating surface	•	Airlinq Orbit control panel	•
Electric comfort heating surface	•	Airmaster Airlinq® Online	•
Water heating surface	•	Airlinq® Online API	•
Condensate pump	•	Airlinq® BMS	•
PIR/motion sensor (wall-mounted)	•	LON® module	o
CO ₂ -sensor (wall-mounted)	•	KNX® module	o
CO ₂ -sensor (built-in)	•	MODBUS® RTU RS485 module	•
TVOC-sensor (built-in)	•	BACnet™ MS/TP module	•
CO ₂ -/TVOC-sensor (built-in)	•	BACnet™ /IP module	•
Hygostat (wall-mounted)	o		

X : Standard • : Optional o : Special item (not stock item)

Schematic sketch

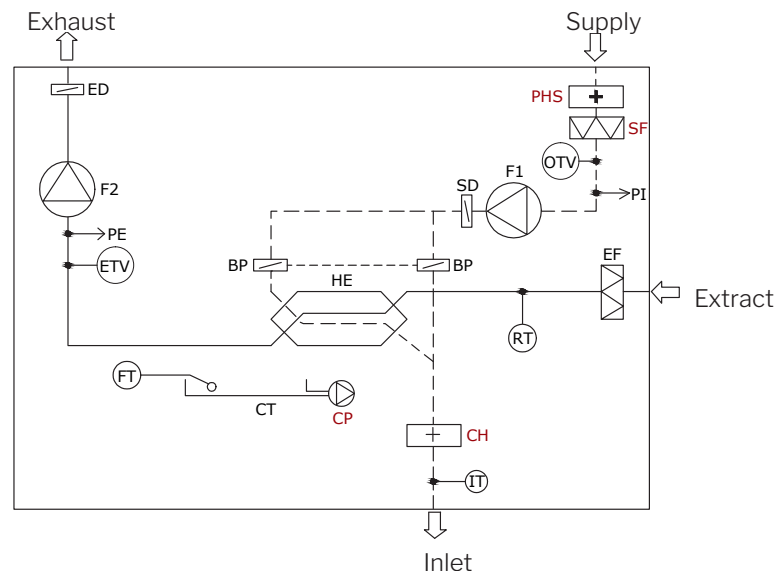

Component designation

BP	Bypass damper (motor-driven)	EF	Extract air filter	OTV	Supply air temperature sensor
CH	Electric comfort heating surface (option)	ETV	Exhaust temperature sensor	PE	Flow meter, extracted air
CP	Condensate pump (option)	FT	Float	PHS	Preheating surface (option)
CT	Condensate tray	F1	Supply air fan	PI	Flow meter, supply air
ED	Exhaust air damper (motor-driven)	F2	Extract air fan	RT	Room temperature sensor
		HE	Counterflow heat exchanger	SD	Supply air damper (motor-driven)
		IT	Inlet-air temperature sensor	SF	Supply air filter (option)