

## AM 1000

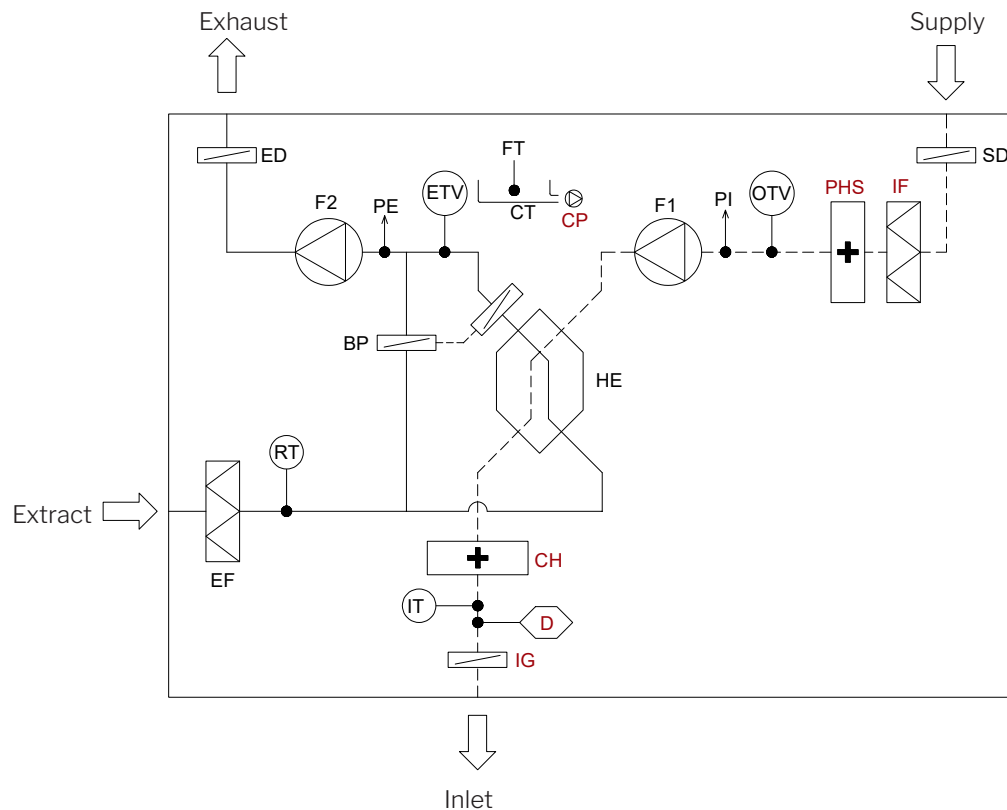

### Component designation

BP	Bypass damper (motor-controlled)
CH	Electrical comfort heating surface (option)
CP	Condensate pump (option)
CT	Condensate tray
D	Smoke detector (option)
ED	Exhaust damper (motor-controlled)
EF	Extract air filter
ETV	Exhaust temperature sensor
FT	Float
F1	Outdoor air fan
F2	Exhaust air fan
HE	Counterflow heat exchanger
IF	Outdoor air filter (option)
IG	Adaptive Airflow™ (option)
IT	Supply air temperature sensor
OTV	Outdoor air temperature sensor
PE	Flow meter, extract air
PHS	Electric preheating surface (option)
PI	Flow meter, supply air
RT	Room temperature sensor
SD	Supply damper (motor-controlled)