



## Data Sheet AM 150 / CC 150

Technical data	Filter class	30 dB(A)	35 dB(A)	Boost
Maximum capacity <sup>1</sup>	ePM <sub>10</sub> 50%	115 m <sup>3</sup> /h	147 m <sup>3</sup> /h	216 m <sup>3</sup> /h
	ePM <sub>1</sub> 55%	90 m <sup>3</sup> /h	126 m <sup>3</sup> /h	197 m <sup>3</sup> /h
	ePM <sub>1</sub> 80%	85 m <sup>3</sup> /h	115 m <sup>3</sup> /h	180 m <sup>3</sup> /h
Throw (0,2 m/s) <sup>2</sup>	ePM <sub>10</sub> 50%	2,6 m	3,4 m	4,6 m
	ePM <sub>1</sub> 55%	2,1 m	2,8 m	4,2 m
	ePM <sub>1</sub> 80%	1,9 m	2,6 m	3,8 m
Supply air filter	ePM <sub>10</sub> 50%, ePM <sub>1</sub> 55% or ePM <sub>1</sub> 80%			
Extract air filter	ePM <sub>10</sub> 50%			
Dimensions (WxHxD)	1170 x 261 x 862 mm			
Weight, standard unit, complete (AM 150 + CC 150)	82 kg (53 kg + 29 kg)			
Weight, casing (AM 150 + CC 150)	60 kg (40 kg + 20 Kg)			
Weight, service cover (AM 150 + CC 150)	22 kg (13 kg + 9 kg)			
Colour, casing	RAL 9010 (white)			
Counterflow heat exchanger	PET (Polyethylene terephthalate)			
Energy class, cf. EU regulation no. 1254	SEC class A			
Air leakage classification cf. EN1886/EN13141-7	Class L1 / Class A1			
Air leakage classification, main damper, cf. EN1751	Class 3			
IP code	10			
Duct connection	Ø125 mm			
Condensate pump (capacity/lifting height at 5 l/h)	10 l/h / 6 m			
Condensate drain hose int./ext. diameter	Ø4 mm / Ø6 mm			
Supply voltage	220-240V/50Hz, ~1N+PE			
Maximum ; nominal power consumption at 30 dB(A) / 35 dB(A) / Boost <sup>1</sup>	185 W ; 28 W / 48 W / 92 W			
Maximum ; nominal current at 30 dB(A) / 35 dB(A) / Boost <sup>1</sup>	1,35 A ; 0,25 A / 0,38 A / 0,69 A			
Power factor	0,59			
Maximum fuse	13 A (1 phase, type B). When using the cc module, it is type C			
Leakage current AC (AM; CC) / DC	≤ 0,52 mA ; ≤ 1,5 mA / ≤ 0,0007 mA			
Recommended residual current circuit breaker (RCCB)	Type B			

### AM 150 + CC 150 cooling module

Energy class, cf. EU regulation no. 626/2011	SEC class A+++
Nominal ; min. cooling duty <sup>4</sup>	700 W ; 146 W
Nominal EER	4,3
Max. ; nominal power consumption	249 W ; 162 W
Max. ; nominal current	1,84 A ; 1,1 A
Minimum airflow for activating the cooling module	50 m <sup>3</sup> /h
Refrigerant ; filling ; GWP	R134a ; 180g ; 1430

### Electrical heating surfaces

Heat output	500 W	1000 W <sup>3</sup>
Nominal current	2,17 A	4,35 A
Thermal circuit breaker, manual reset	100 °C	100 °C

<sup>1</sup> All measurements were performed in normal operating mode in a standard installation for the filter class, supply/extract air: ePM<sub>10</sub> 50% / ePM<sub>10</sub> 50%, using the facade grills recommended by Airmaster, in a test room dimensioned 8.0 m x 10.0 m x 2.5 m with room attenuation of 7.5 dB. For small spaces, e.g. 4.0 m x 4.0 m x 2.5 m, 2 dB sound pressure must be added.

<sup>2</sup> The throw is measured with a 2 °C subcooled supply air at the standard setting of the inlet diffuser. The setting is adaptable, see page 6.

<sup>3</sup> Special item

<sup>4</sup> Cf. EN 308, EN 14511 and EN 14825 at 147 m<sup>3</sup>/h ; 50 m<sup>3</sup>/h.

## Capacity<sup>5</sup> with ePM<sub>10</sub> 50% / ePM<sub>10</sub> 50% filters

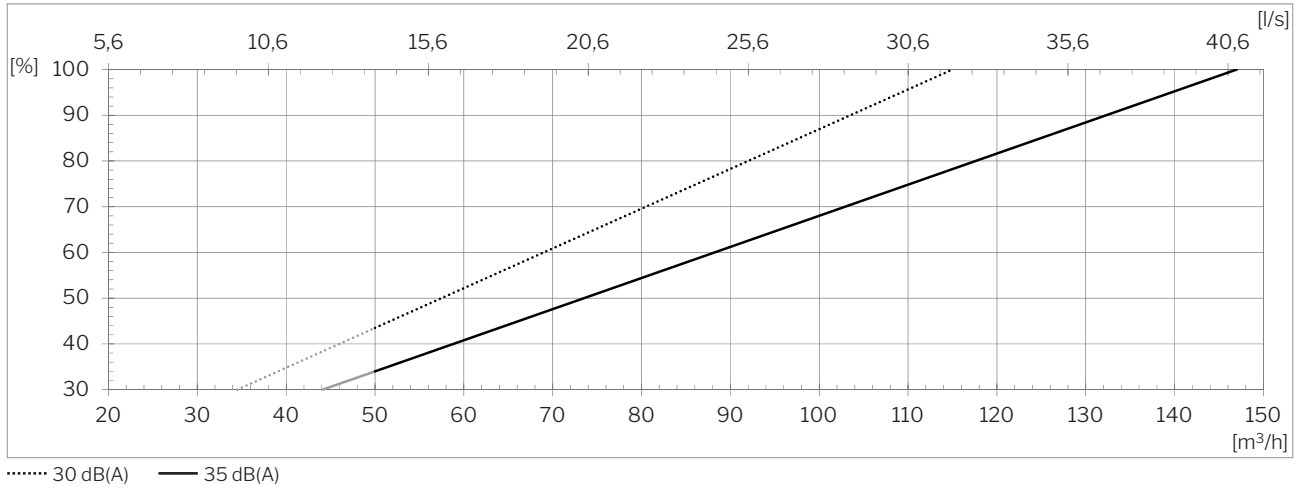

## Capacity<sup>5</sup> with ePM<sub>1</sub> 55% / ePM<sub>10</sub> 50% filters

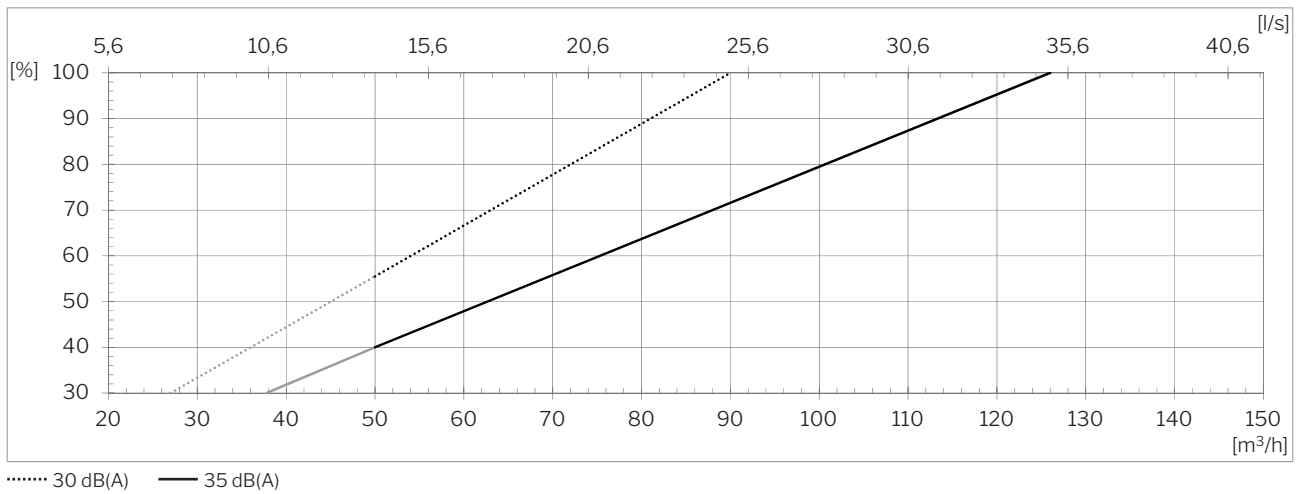

## Capacity<sup>5</sup> with ePM<sub>1</sub> 80% / ePM<sub>10</sub> 50% filters

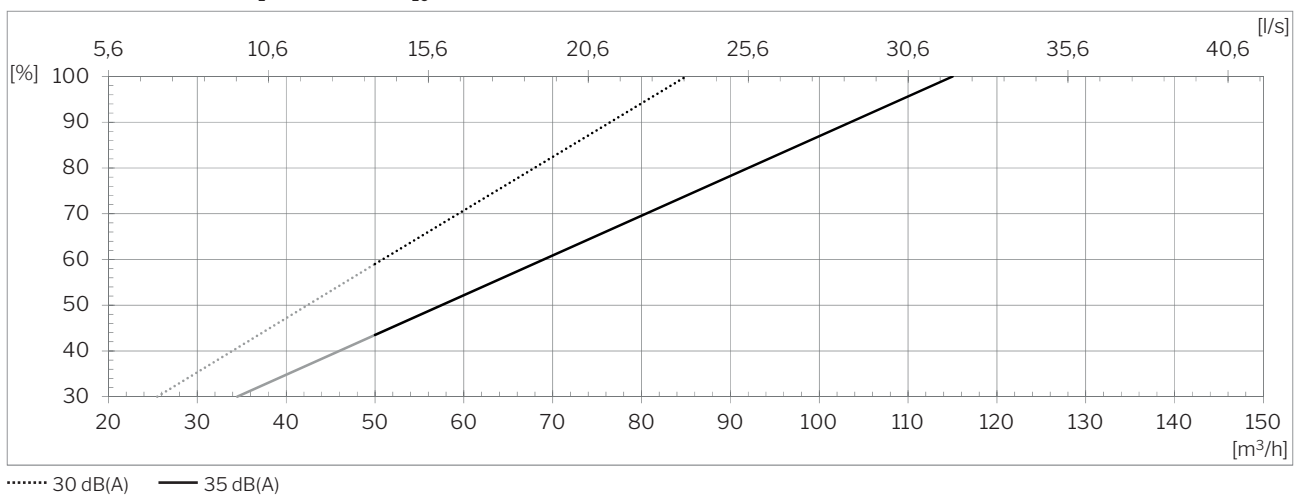

<sup>5</sup> Minimum airflow for activating the cooling module : 50 m³/h.

## SFP with ePM<sub>10</sub> 50% / ePM<sub>10</sub> 50% filters

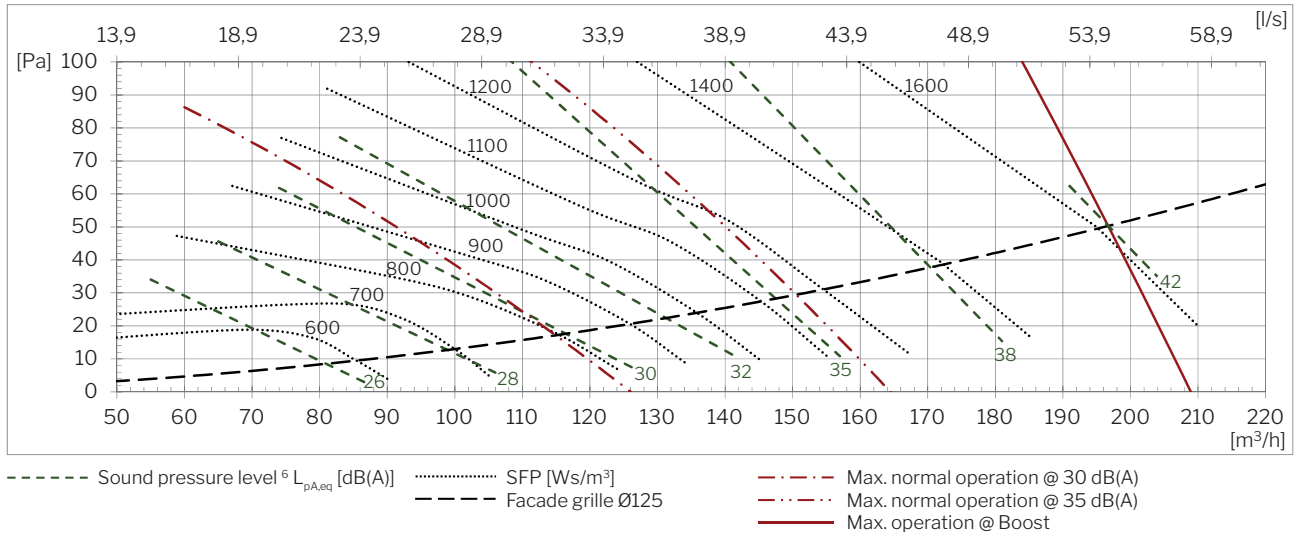

## SFP with ePM<sub>1</sub> 55% / ePM<sub>10</sub> 50% filters

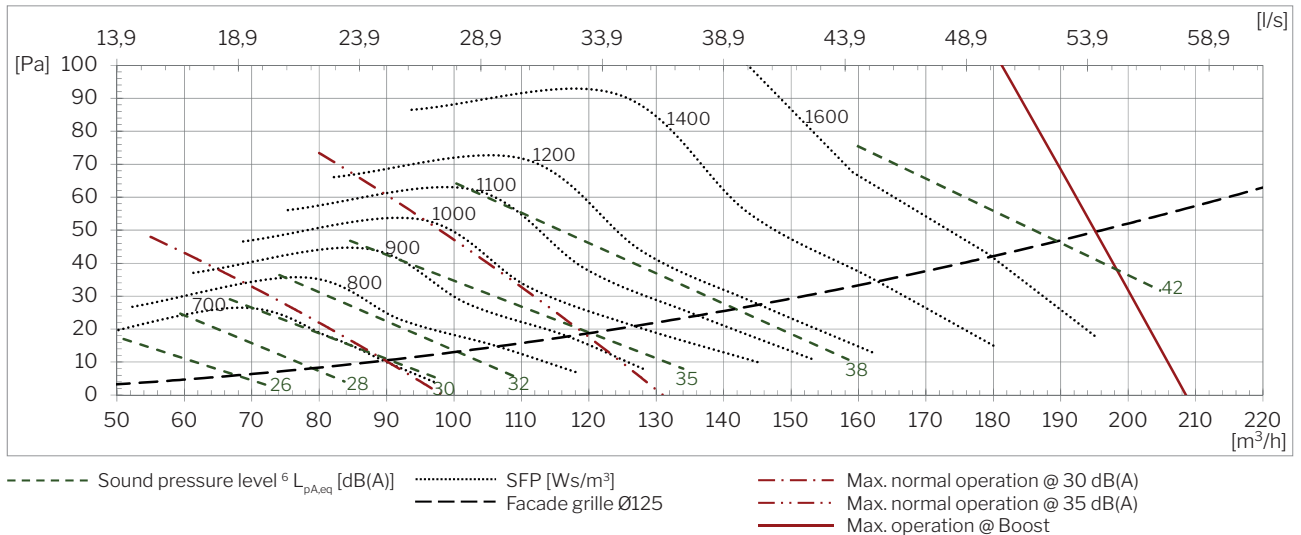

## SEL med ePM<sub>1</sub> 80% / ePM<sub>10</sub> 50% filtre:

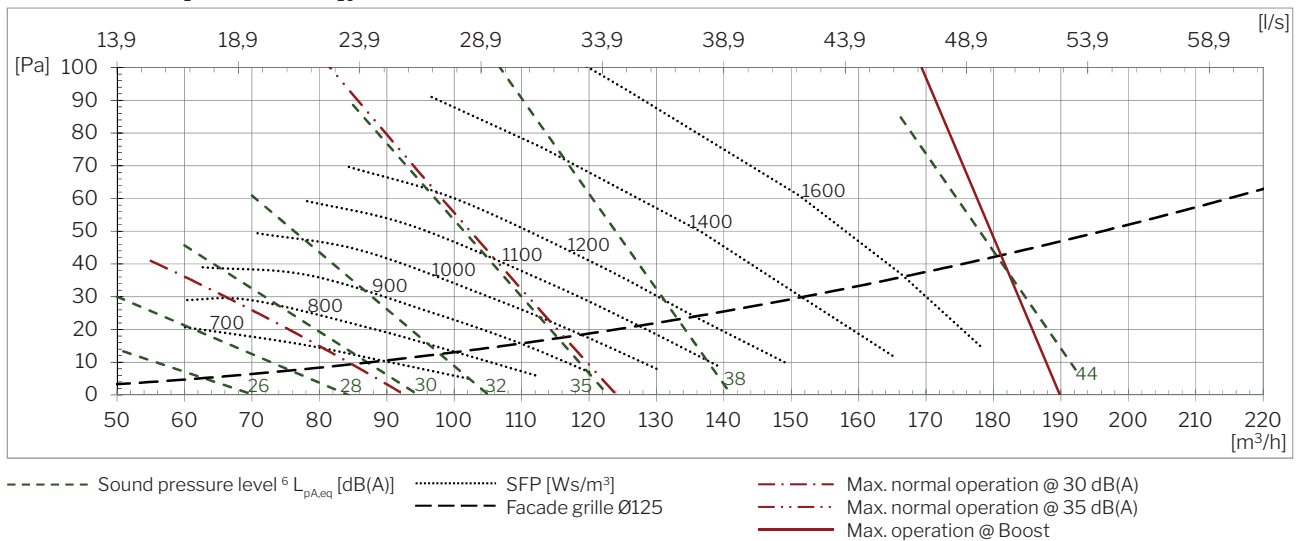

<sup>6</sup> The sound pressure level L<sub>pA,eq</sub> is measured at a height of 1,2 m at a horizontal distance of 1 m from the air handling unit.

## Sound pressure level <sup>7</sup>L<sub>pA,eq</sub> acc. to Airmaster reference situation

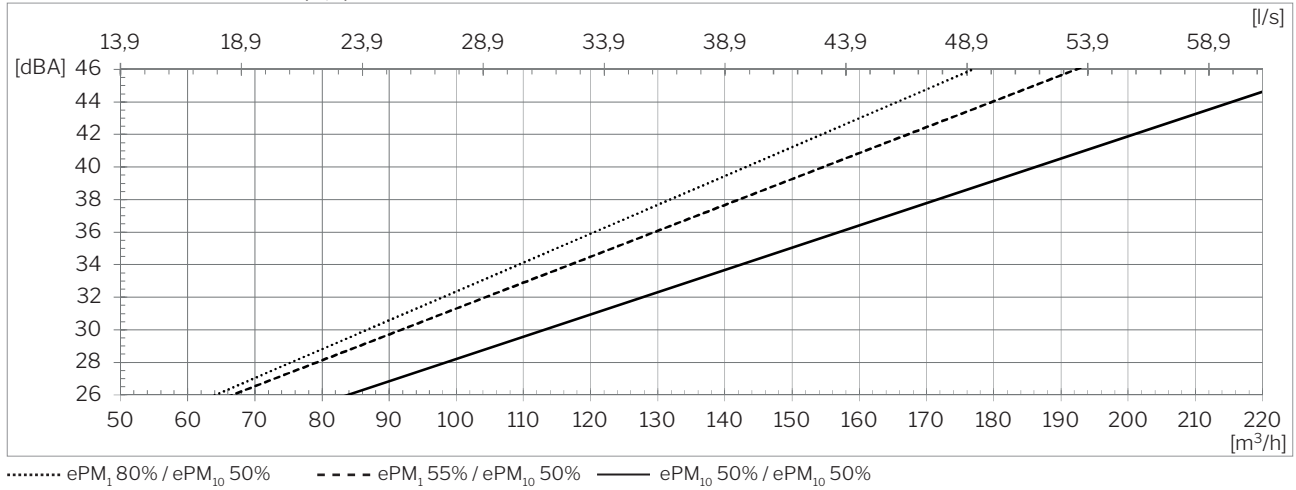

## Temperature efficiency acc. to EN 308

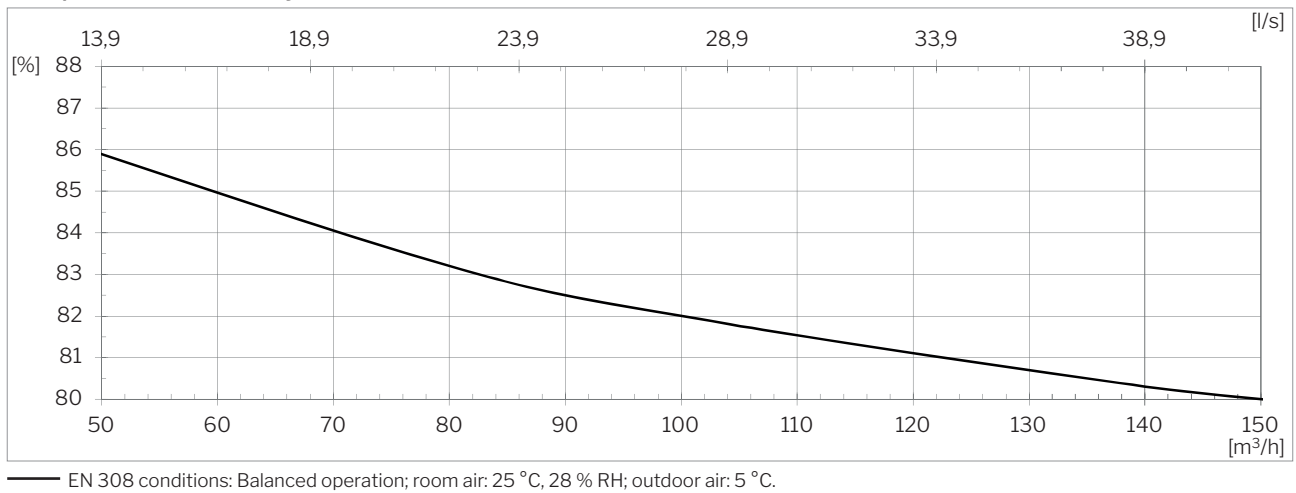

## Power consumption

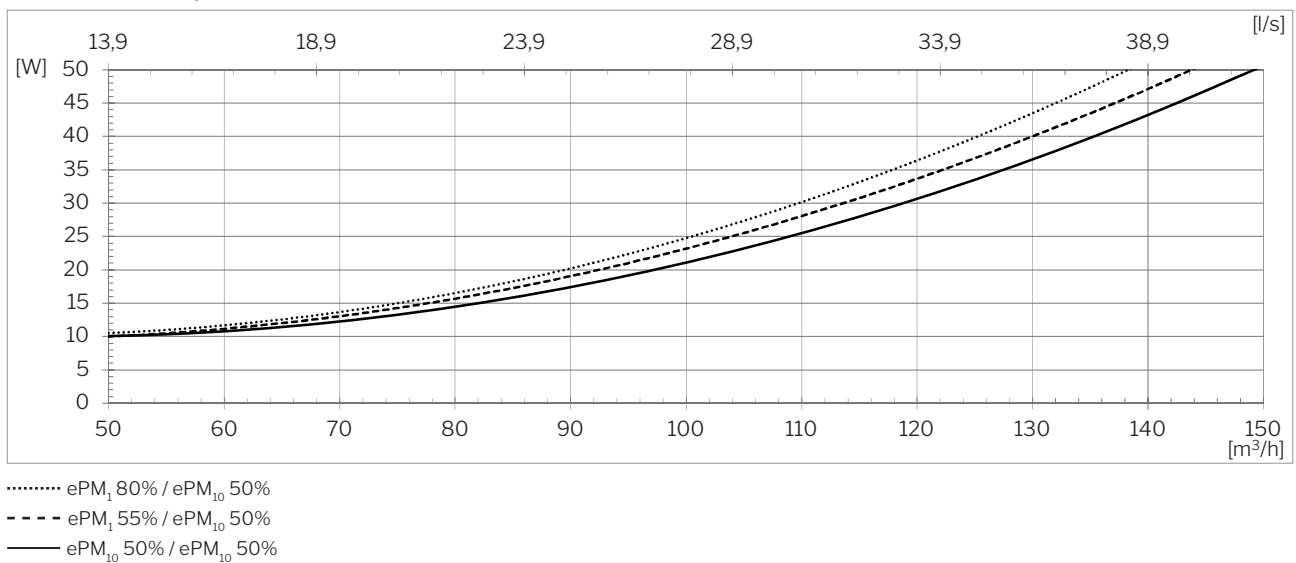

<sup>7</sup> The sound pressure level L<sub>pA,eq</sub> is measured at a height of 1.2 m at a horizontal distance of 1 m from the air handling unit.

## SFP<sup>8</sup>

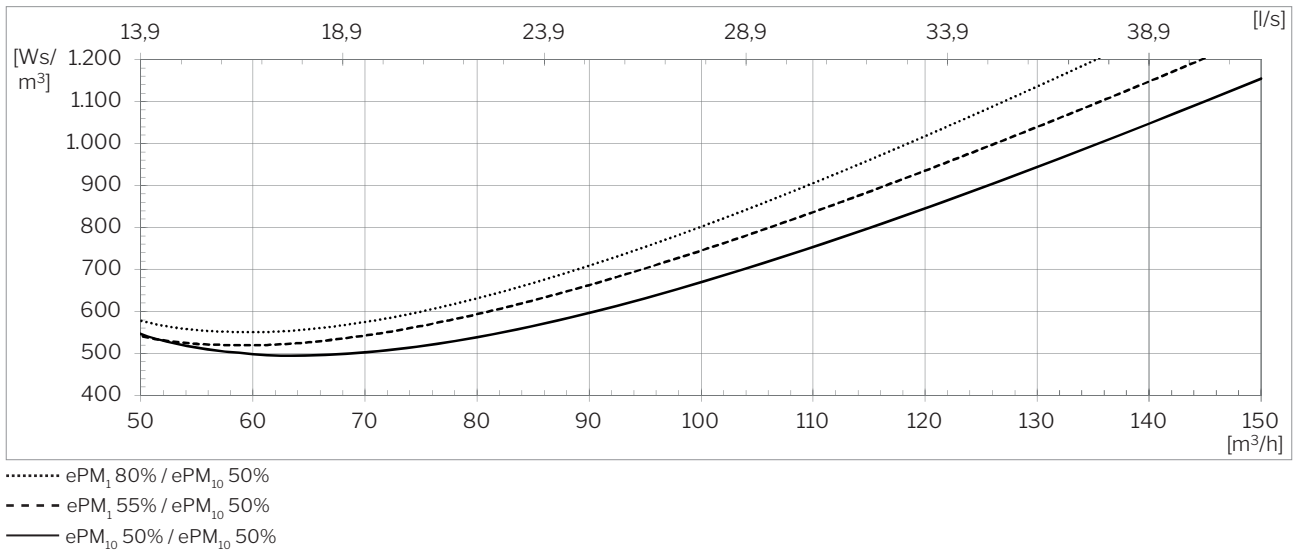

<sup>8</sup> The calculation of SFP includes the power consumption for operating fans but not for controls, display panel, etc.

Throw<sup>9</sup> (0,2 m/s)

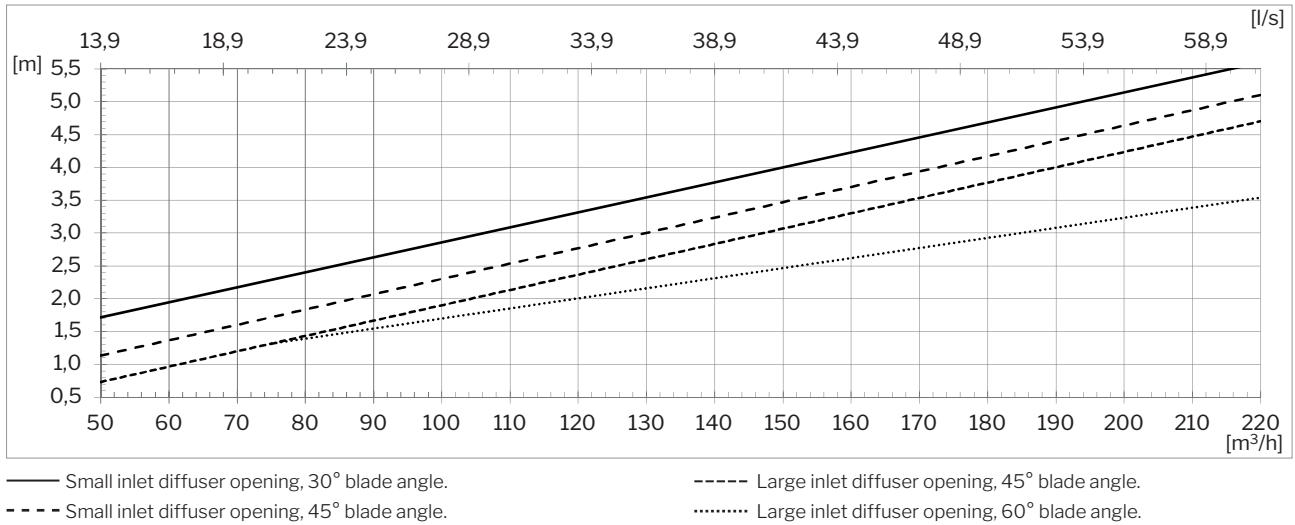

### Small and large inlet diffuser opening

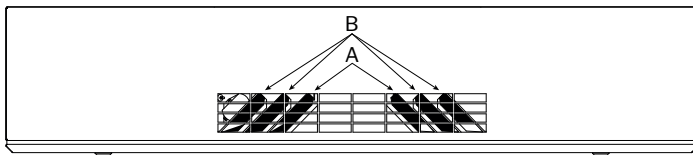

Small inlet diffuser opening:  
A is closed, B is open at  $x^\circ$ .

Large inlet diffuser opening:  
A and B are open at  $x^\circ$ .

Default delivery state:  
Small inlet diffuser opening, 45° blade angle.

Throw and dispersion, top view.

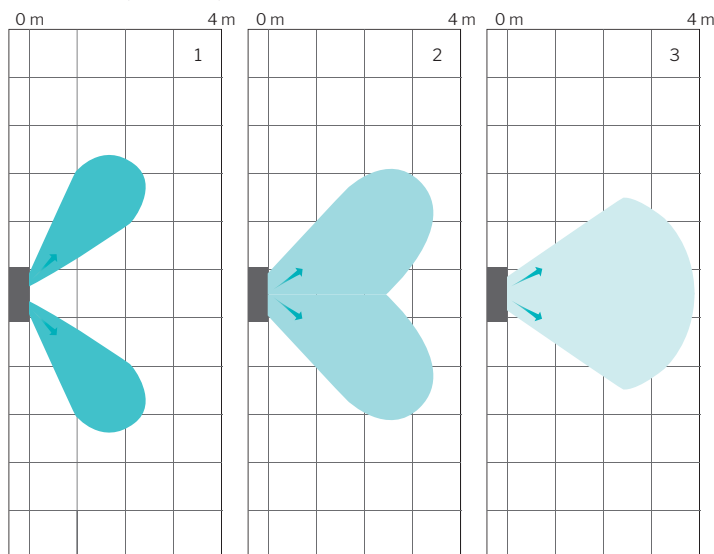

The air handling unit disperses inlet air depending on the blade angle settings.

The illustrations show the dispersion pattern and throw for the various blade angle settings at an air flow of 147 m³/h:

1. Large inlet diffuser opening, 60° blade angle.
2. Small inlet diffuser opening, 45° blade angle.
3. Small inlet diffuser opening, 30° blade angle.

Changing the air flow also affects the throw length.

Throw, side view.

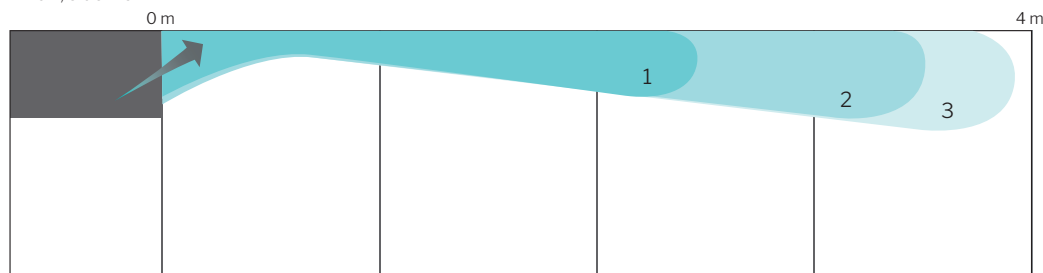

<sup>9</sup> The throw is measured with a 2 °C subcooled inlet air supply.

## Version overview

### AM 150 with CC 150 (Comfort Cooling Module (CC))

Exhaust/supply position  
» Back (**H**orizontal)

Inlet/extract position  
» Bottom (**B**)  
» Ducted Inlet (**DI**)  
» Ducted Extract (**DE**)

Mounting  
» Wall/ceiling bracket

H BB - CC

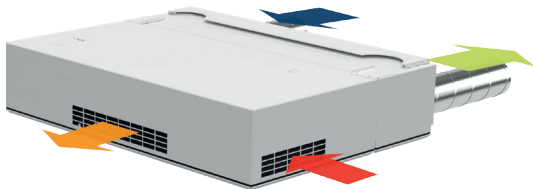

H BDE - CC

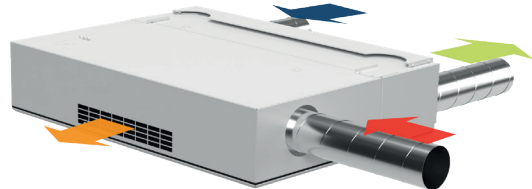

H DIB - CC<sup>10</sup>



H DIDE - CC<sup>10</sup>

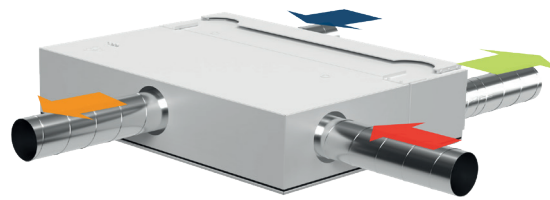

## Standards and options

Counterflow heat exchanger (PET)	x
Enthalpy counterflow heat exchanger (polymer membrane)	o
Combination counterflow heat exchanger (polymer membrane)	o
Motor-driven bypass	x
Motor-driven supply air damper	x
Motor-driven extract air damper	x
Electric heating surface/VPH <sup>11</sup>	•
Condensate pump	•
PIR/motion sensor (wall mounted)	•
PIR/motion sensor (integrated)	•
CO <sub>2</sub> sensor (wall mounted)	•
CO <sub>2</sub> sensor (integrated)	•
TVOC (integrated)	•
CO <sub>2</sub> -/TVOC sensor (integrated)	•
Hygrostat (wall mounted)	o
Energy meter	•
Supply air filter ePM <sub>10</sub> 50%	•

Supply air filter ePM <sub>1</sub> 55%	•
Supply air filter ePM <sub>1</sub> 80%	o
Extract air filter ePM <sub>10</sub> 50%	x
LED (operating mode indicator)	x
Comfort cooling module	•
Wall/ceiling bracket	•
Ceiling frame	•
Operating button	•
Control panel, Viva	•
Control panel, Orbit	•
Airmaster Airlinq® Online	•
Airlinq® Online API	•
Airlinq® BMS	•
LON® module	o
KNX® module	o
MODBUS® RTU RS485 module	•
BACnet™ MS/TP module	•
BACnet™ /IP module	•

X : Standard    • : Optional    o : Special item (not stock item)

<sup>10</sup> Special item

<sup>11</sup> Virtual PreHeat

## Schematic sketch

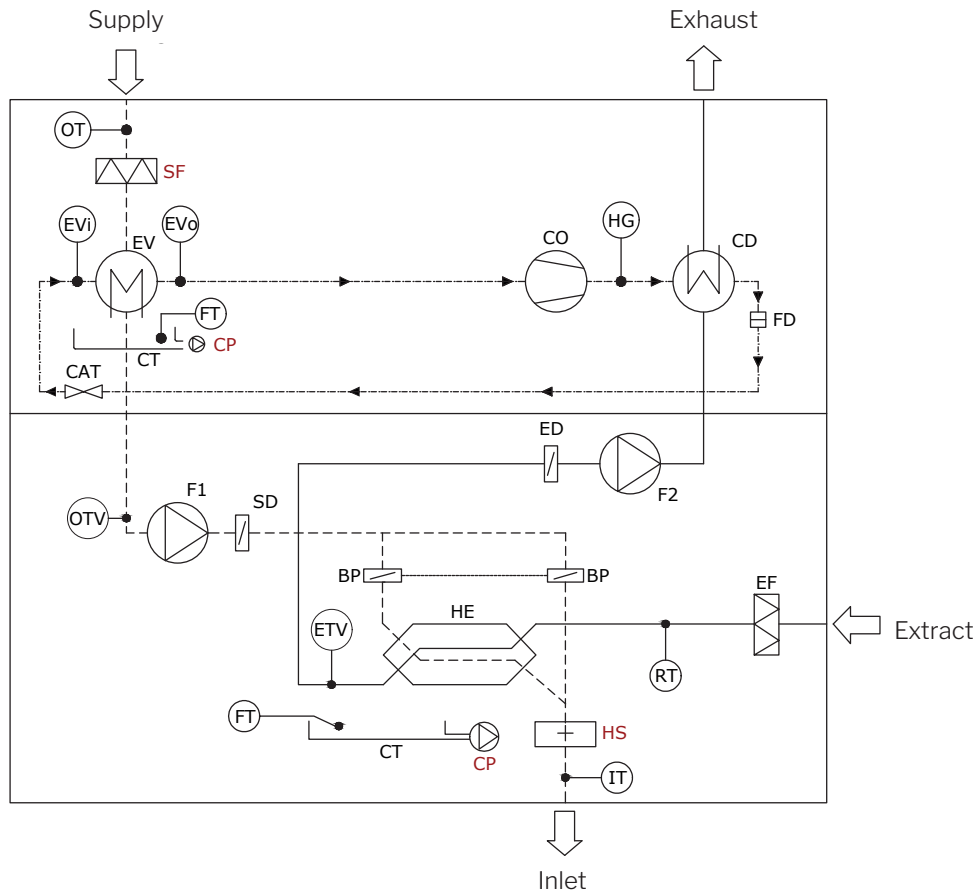

### Component designation

BP	Bypass damper (motor-driven)	EV	Evaporator	HS	Electric heating surface (option)
CAT	Capillary Tube	EVi	Temperature sensor, Evaporator in	IT	Temperature sensor, Inlet-air
CD	Condenser	EVo	Temperature sensor, Evaporator out	OT	Temperature sensor, Supply air
CO	Compressor, inverter Controlled	FD	Filter Dryer	OTV	Temperature sensor, Supply air ventilation
CP	Condensate pump (option)	FT	Float	RT	Temperature sensor, Room
CT	Condensate tray	F1	Supply air fan	SD	Supply air damper (motor-driven)
ED	Exhaust air damper (motor-driven)	F2	Extract air fan	SF	Supply air filter (option)
EF	Extract air filter	HE	Counterflow heat exchanger		
ETV	Temperature sensor, Exhaust, Ventilation	HG	Temperature sensor, Hot Gas		