

Technical data

	Filter class	30 dB(A)	35 dB(A)	Boost
Maximum capacity ^A	ePM ₁₀ 50%	222 m ³ /h	288 m ³ /h	315 m ³ /h
	ePM ₁ 55%	220 m ³ /h	284 m ³ /h	310 m ³ /h
Throw (0,2 m/s) ^B	ePM ₁₀ 50%	4.5 m	6.3 m	7 m
	ePM ₁ 55%	4.5 m	6.3 m	7 m
Operating range (max. capacity), outside temperature		-15 °C - 40 °C		
Supply air filter		ePM ₁₀ 50%, ePM ₁ 55% or ePM ₁ 80%		
Extract air filter		ePM ₁₀ 50%		
Dimensions (WxHxD)		2055 x 358 x 1100 mm		
Weight: standard air handling unit, complete		235 kg		
Weight: casing		175 kg		
Weight: service cover		55 kg		
Color: casing / panels and service cover		RAL 9005 (Jet Black) / RAL 9010 (Pure white)		
Counterflow heat exchanger		Aluminium		
Energy class, cf. EU regulation no. 1254/2014		SEC class A		
Air leakage classification cf. EN 1886 / EN 13141-7		Class L2 / A1		
Air leakage classification, main damper, cf. EN 1751		Class 3		
IP code		10		
Duct connection		Ø200 mm		
Condensate pumps: capacity / lifting height (at 5 l/h)		10 l/h / 6 m		
Condensate drain hose: internal diameter / external diameter		Ø6 mm / Ø9 mm		
Supply voltage		220-240V/50Hz, ~1N+PE		
Maximum power; nominal power consumption at 30 dB(A) / 35 dB(A) / Boost ^A (including heat pump)		2560 W; 406 / 570 / 802		
Maximum current; nominal current at 30 dB(A) / 35 dB(A) / Boost ^A (including heat pump)		11.2 A; 1.79 / 2.51 / 3.53		
Power factor (including heat pump)		0,92		
Maximum fuse		16 A, 1 phase, type C		
Leakage current AC / DC		6 mA / 0.04 mA		
Recommended residual current circuit breaker (RCCB)		Type B		

^A All measurements were performed in a normal operating mode in a standard installation in a test room, dimensioned 8.0 m x 10.0 m x 2.5 m with room attenuation of 8 dB(A).

^B The throw is measured with a 3-5°C subcooled supply air in a test room, dimensioned 8.0 m x 10.0 m x 2.5 m.

Electrical heating surfaces

	Heating surface 1	Heating surface 2
Heat output	1150 W	1150 W
Nominal current	5 A	5 A
Thermal circuit breaker, manual reset	100°C	100°C

Heat pump

Nominal cooling output ^C	2000 W
Nominal heat output ^C	2300 W
Materials: pipes / fins	Copper / Aluminium
COP (heating) ventilation	5.7 – 7.4
COP (heating) recirculation	3.6
EER (cooling) ventilation	2.3 – 3.8
Refrigerant / GWP ^D	R290 / 0.02
Filling	330 g

^C cf. DS/EN 308 and DS/EN 14825.

^D cf. (EU) 2024/573.

Capacity at 30 dB(A) sound pressure level^A

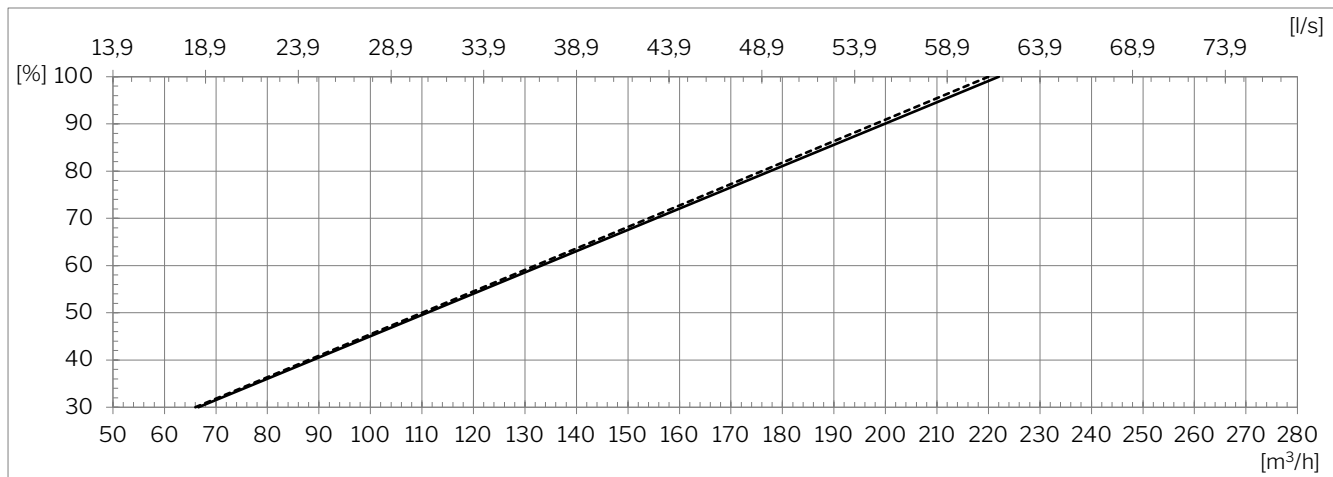

— Supply air filter ePM₁₀ 50% + extract air filter ePM₁₀ 50%

--- Supply air filter ePM₁ 55% + extract air filter ePM₁₀ 50%

Capacity at 35 dB(A) sound pressure level^A

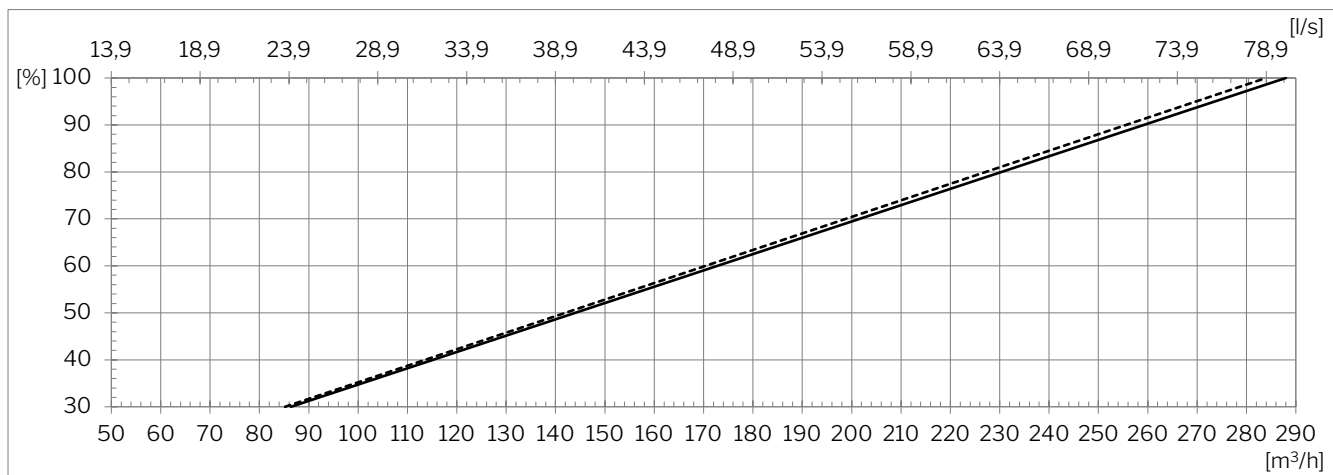

— Supply air filter ePM₁₀ 50% + extract air filter ePM₁₀ 50%

--- Supply air filter ePM₁ 55% + extract air filter ePM₁₀ 50%

SFP with supply air filter ePM₁₀ 50% + extract air filter ePM₁₀ 50%

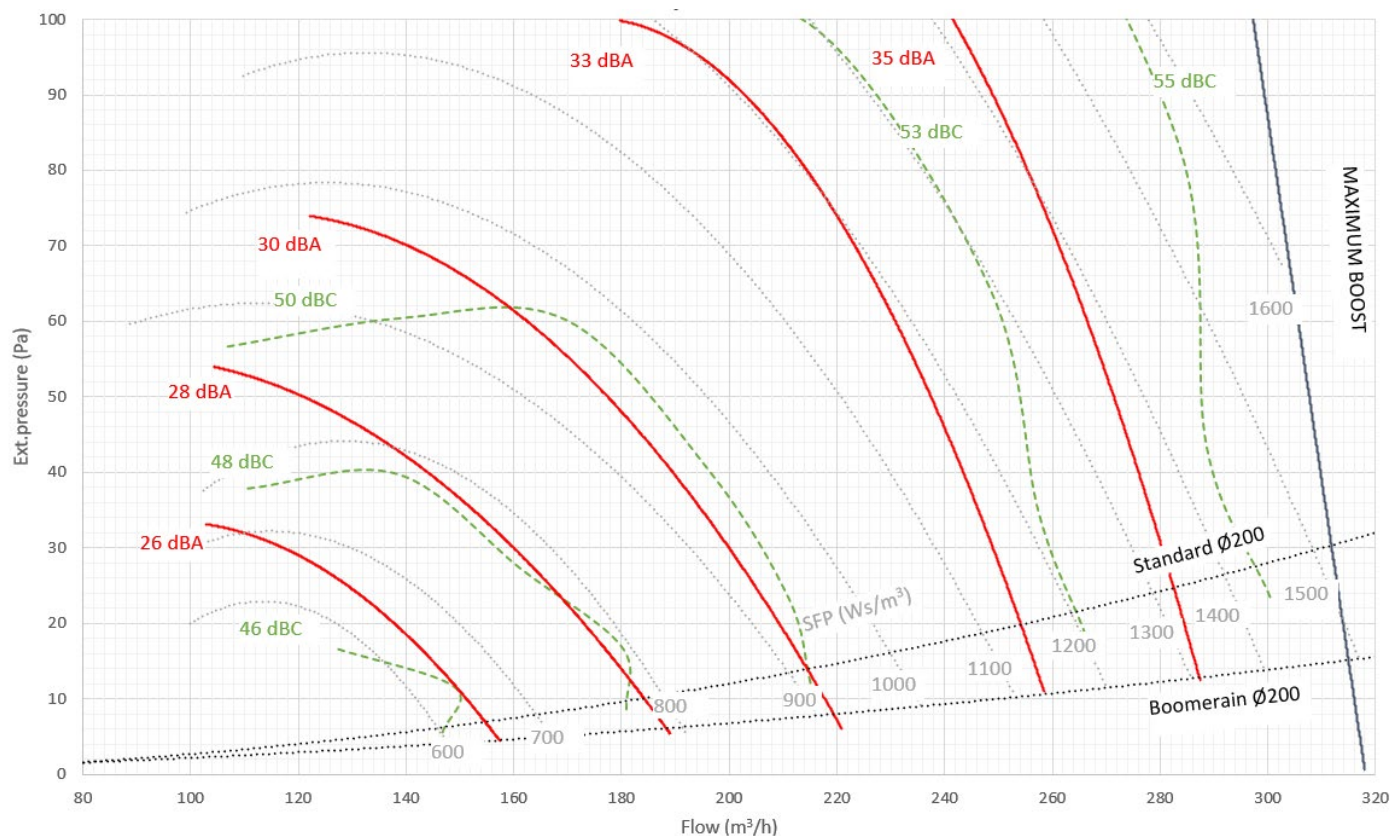

SFP with supply air filter ePM₁ 55% + extract air filter ePM₁₀ 50%

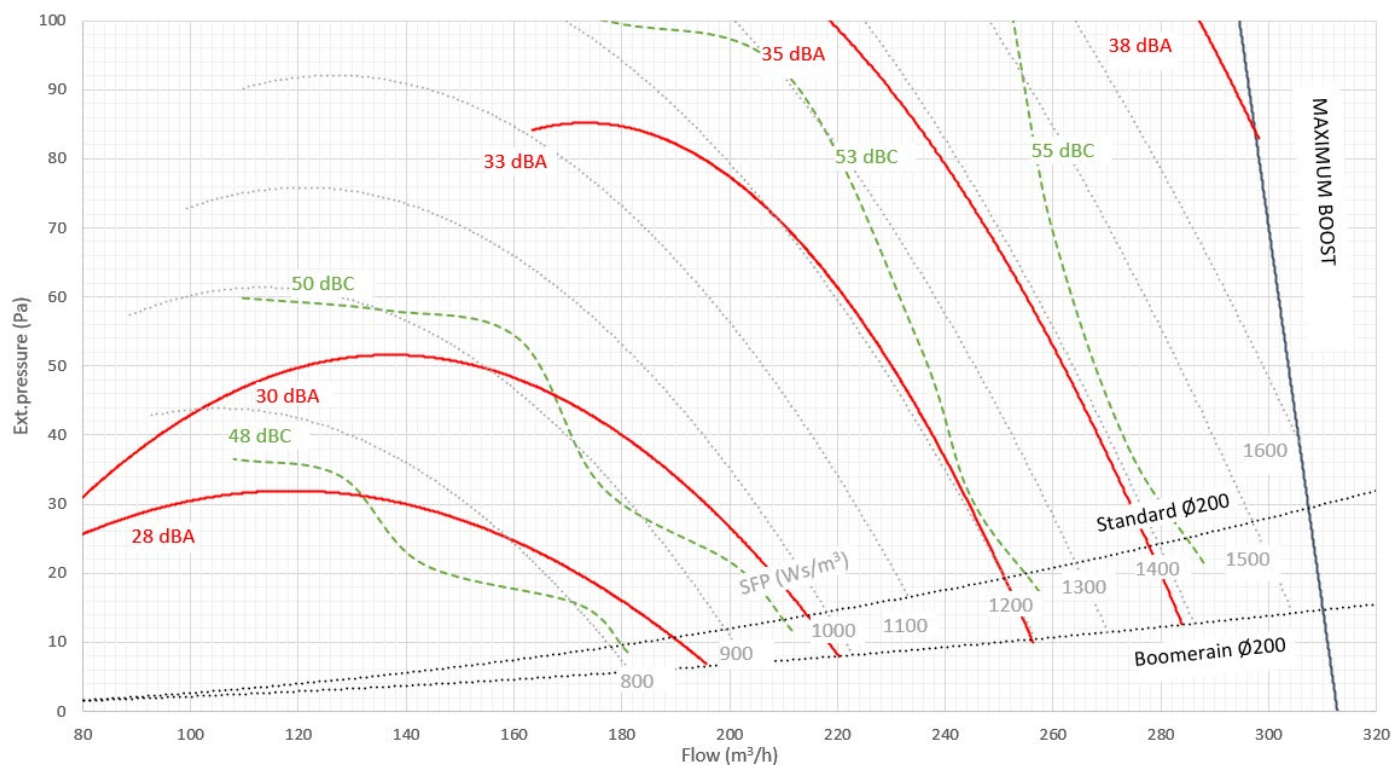

Sound pressure level L_{PA} acc. to Airmaster reference situation^E

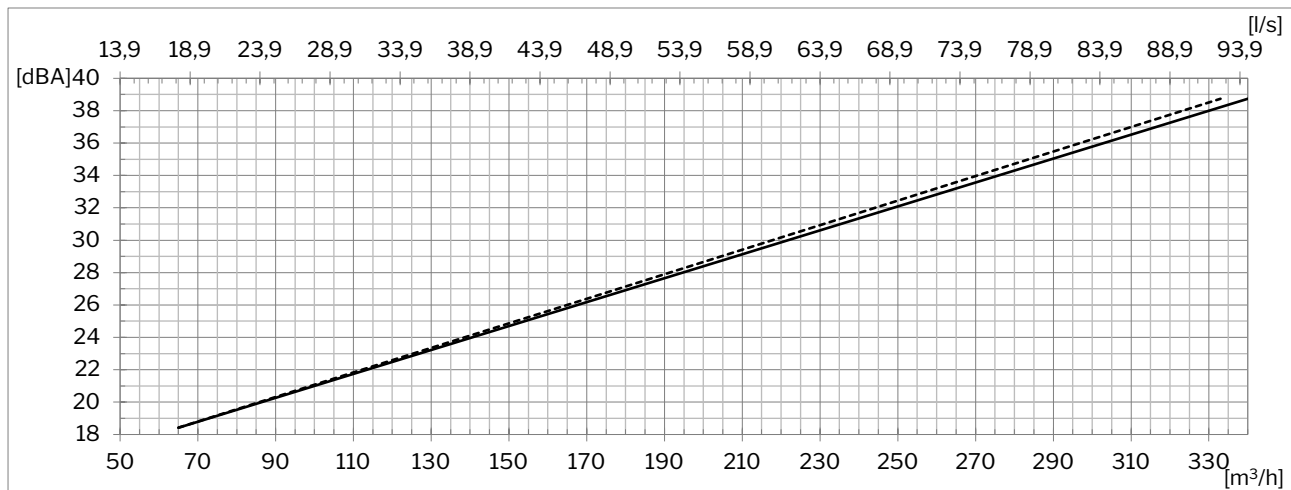

— Supply air filter ePM₁₀ 50% + extract air filter ePM₁₀ 50%

---- Supply air filter ePM₁ 55% + extract air filter ePM₁₀ 50%

Temperature efficiency acc. to EN 308

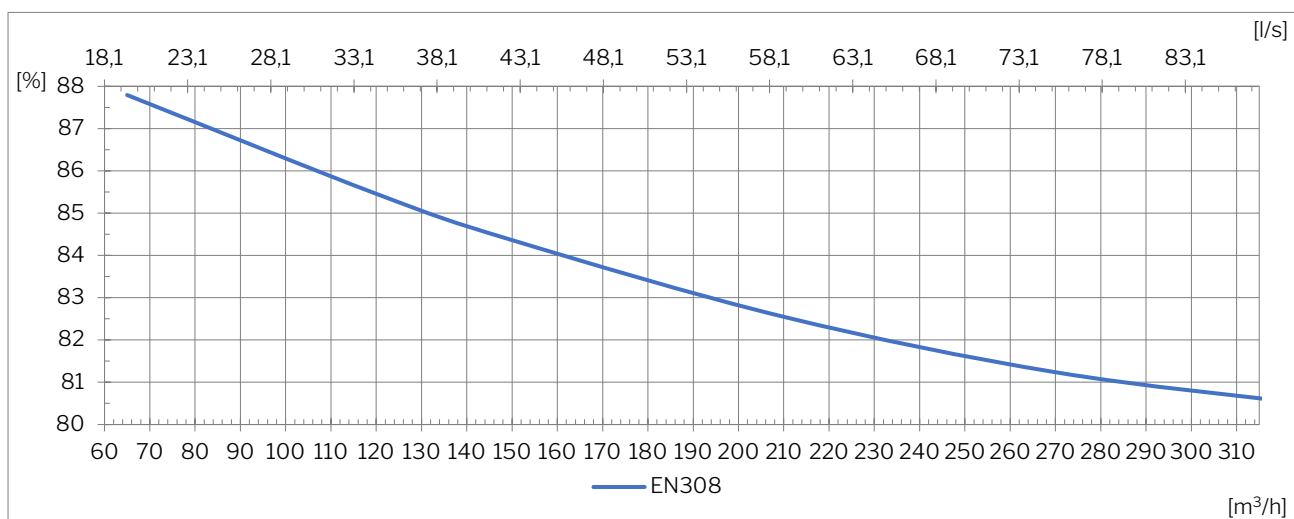

^E The sound pressure level is measured at a height of 1.2 m at a horizontal distance of 1 m from the air handling unit.

Power consumption

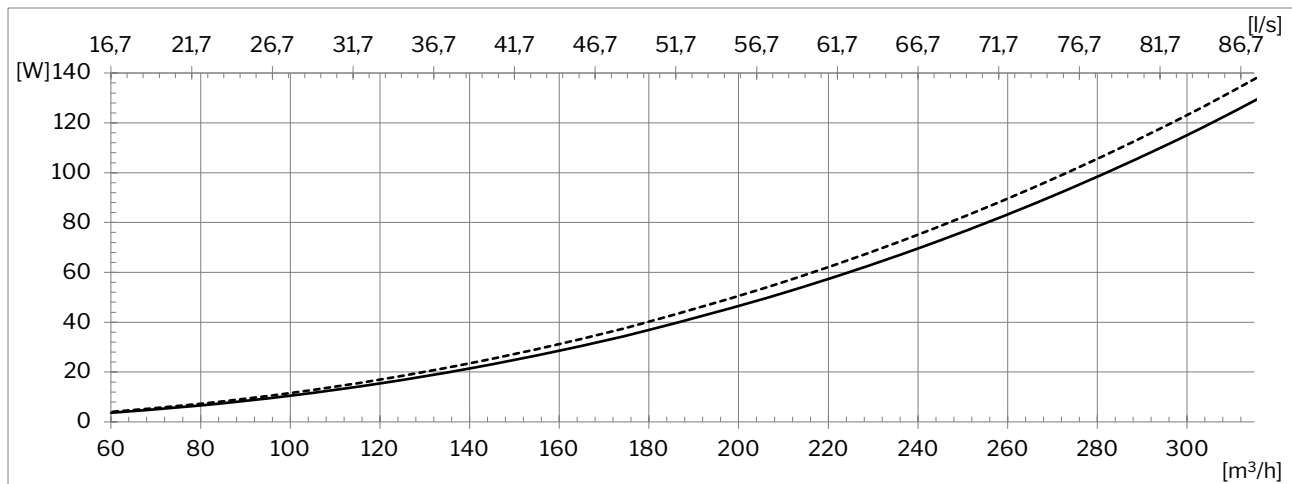

— Supply air filter ePM₁₀ 50% + extract air filter ePM₁₀ 50%

--- Supply air filter ePM₁ 55% + extract air filter ePM₁₀ 50%

SFP^F

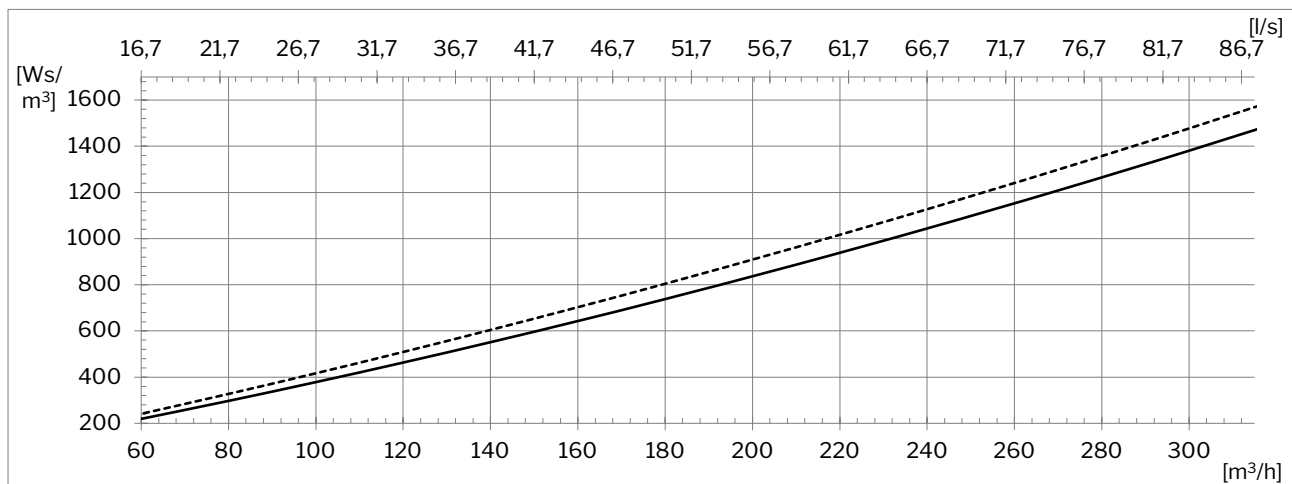

— Supply air filter ePM₁₀ 50% + extract air filter ePM₁₀ 50%

--- Supply air filter ePM₁ 55% + extract air filter ePM₁₀ 50%

^F The SFP calculation includes power consumption for operating fans but not controls, display panels, etc.

Throw at 0.2 m/s

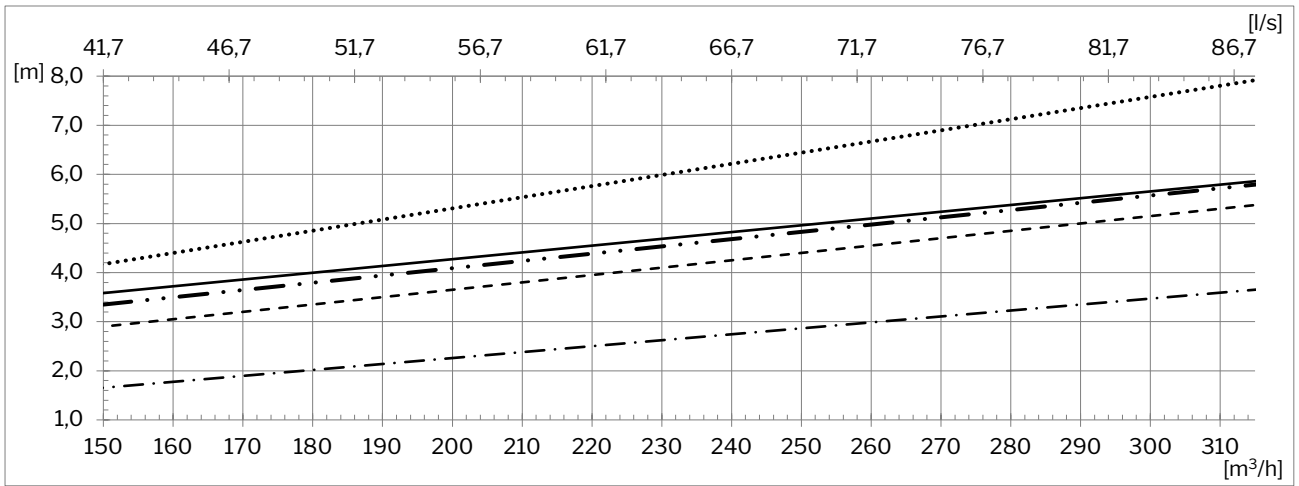

- Reduced diffuser area. 0° blade angle
- 0° blade angle
- - - - - 45° blade angle
- . - . - 60° blade angle
- . - - - Asymmetric. -45°/60° blade angle

Version overview

Exhaust and supply:

H: horizontal



HH



Inlet and extract:

B: bottom

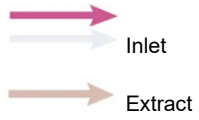

BB



Standards and options

Counterflow heat exchanger (Aluminium)	✓	Supply air filter ePM ₁₀ 50%	opt.
Motor-driven bypass	✓	Supply air filter ePM ₁ 55%	opt.
Motor-driven supply air damper	✓	Supply air filter ePM ₁ 80%	si
Motor-driven extract air damper	✓	Extract air filter ePM ₁₀ 50%	✓
Electric heating surfaces	✓	LED (operating mode indicator)	✓
Condensate pump	✓	Wall/ceiling bracket	✓
Electronic humidity sensor (built-in)	✓	External connection module	opt.
PIR/motion sensor (wall mounted)	opt.	Airmaster Airlinq® Online	opt.
PIR/motion sensor (integrated)	opt.	Airlinq® Online API	opt.
CO ₂ sensor (wall mounted)	opt.	Bluetooth app	✓
CO ₂ sensor (integrated)	✓		
TVOC sensor (integrated)	opt.		

✓: standard opt.: optional si: special item

Schematic sketch

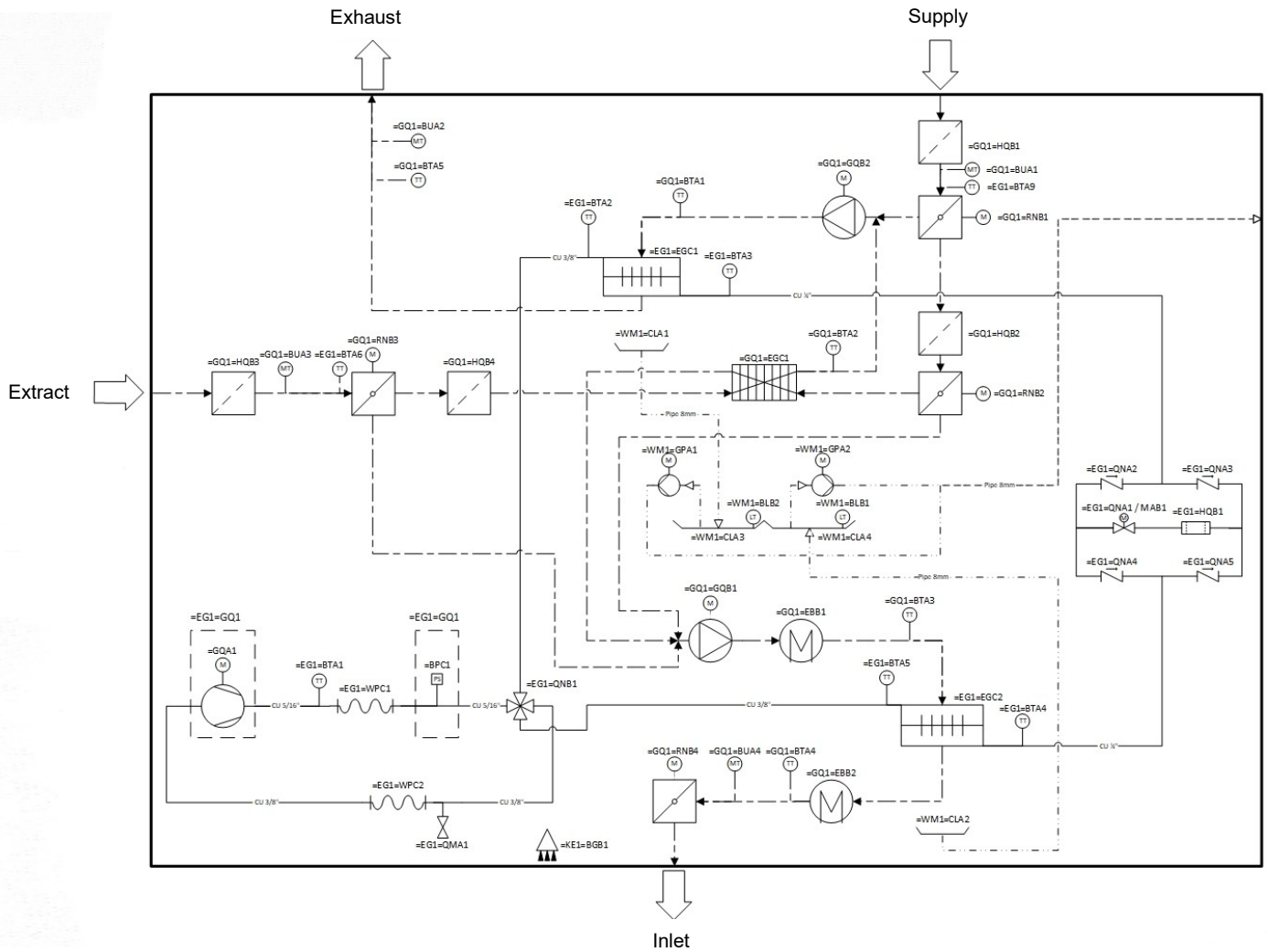

Component designation:

=EG1 Heat pump system
 =EG1=GQ1 Compressor system
 =GQ1 Ventilation system
 =WM1 Condensate system

=BGB PIR
 =BLB Level sensor
 =BPA Pressure transmitter
 =BPC Pressure switch
 =BTA Temperature sensor
 =BUA Humidity/CO₂ sensor

=CLA Condensate tray
 =EBB Heating surface
 =EGC Heat exchanger
 =GPA Condensate pump
 =GQA Compressor
 =GQB Fan

=HQB Filter
 =QMA Filling valve
 =QNA Valve
 =QNB 4-way valve
 =RNB Damper
 =WPC Flexible connection