

Technical data

	Filter class	30 dB(A)	33 dB(A)	35 dB(A)
Maximum capacity ^A	ePM ₁₀ 50%	430 m ³ /h	490 m ³ /h	550 m ³ /h
	ePM ₁ 55%	387 m ³ /h	441 m ³ /h	495 m ³ /h
	ePM ₁ 80%	344 m ³ /h	392 m ³ /h	440 m ³ /h
Throw (0.2 m/s) ^B	ePM ₁₀ 50%	5.9 m	-	7.5 m
	ePM ₁ 55%	5.4 m	-	6.7 m
	ePM ₁ 80%	4.8 m	-	6.0 m
Intake filter	ePM ₁₀ 50%, ePM ₁ 55%, ePM ₁ 80%			
Extract filter	ePM ₁₀ 50%			
Dimensions (Width x Depth x Height)	1600 x 779 x 439 mm			
Weight: standard unit, complete	108 kg			
Color: panel / casing	RAL 9010 (white) / RAL 7024 (grey)			
Counterflow heat exchanger	Aluminium			
Air leakage classification cf. EN 1886 (external leakage)	Class L2			
Air leakage classification cf. EN 13141-7 (external leakage)	Class A2			
Air leakage classification, main damper, cf. EN 1751	Class 3			
IP code	10			
Duct connection	Ø250 mm			
Condensate pump: capacity / lifting head at 5 l/h	10 l/h / 6 m			
Condensate drain hose: internal diameter / external diameter	Ø6 mm / Ø9 mm			
Supply voltage	220-240V/50Hz, ~1N+PE			
Nominal power consumption ^A	354 W			
Maximum current ^A	2.76 A			
Power factor	0.56			
Leakage current AC / DC	≤6mA			
Maximum fuse	13 A, 1 phase, type B. CC module: Type C is required.			
Recommended residual current circuit breaker (RCCB)	Type F / Type B. CC module: Type B is required.			

^A All measurements were performed in normal operating mode in a standard installation using the Airmaster Boomerain® Ø250 facade grills.

^B Throw is measured with ePM₁₀ 50% filters.

Electrical heating surfaces

	Preheating surface	Comfort heating surface
Heat output	1000 W	630 W
Nominal current	4.4 A	2.6 A
Thermal circuit breaker, manual reset	100 °C	100 °C

Water heating surface

Nominal heat output ^c	858 W
Connection dimension	1/2" (DN 15)
Materials pipes/fins	Copper / Aluminium
Opening/closing time motor valve	60 s
Maximum operating temperature	90 °C
Maximum operating pressure	5 bar

^c Heat output for maximum capacity at 35 dB(A), delivery/return temperature 60/40 °C and a liquid flow of 53 l/h.

Capacity with intake filter ePM₁₀ 50% + extract filter ePM₁₀ 50%^A

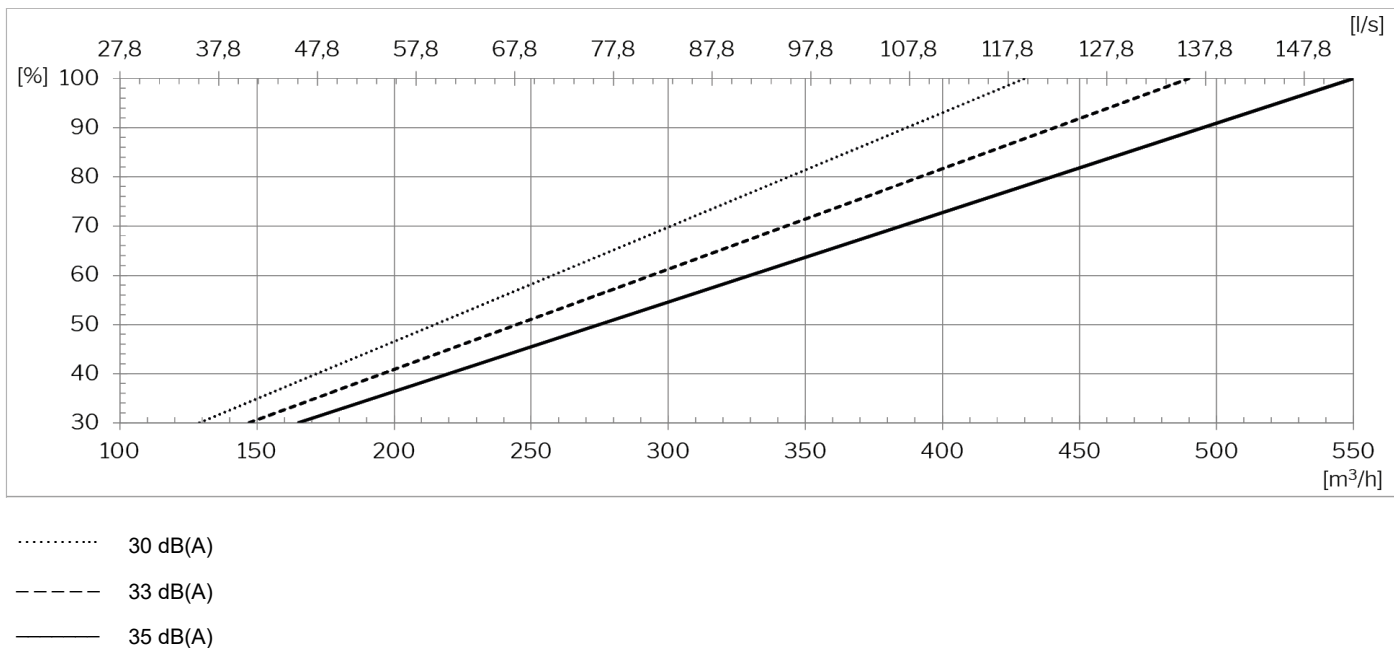

Capacity with intake filter ePM₁ 55% + extract filter ePM₁₀ 50%^A

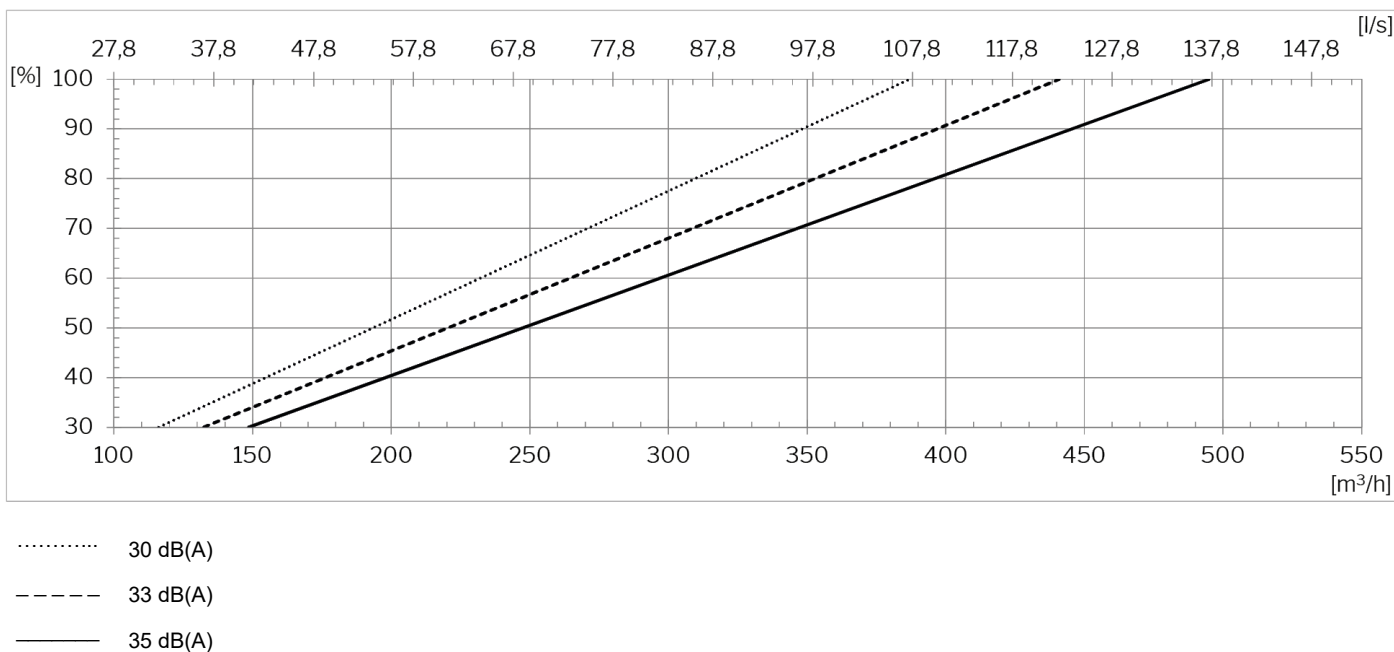

Capacity with intake filter ePM₁ 80% + extract filter ePM₁₀ 50%^A

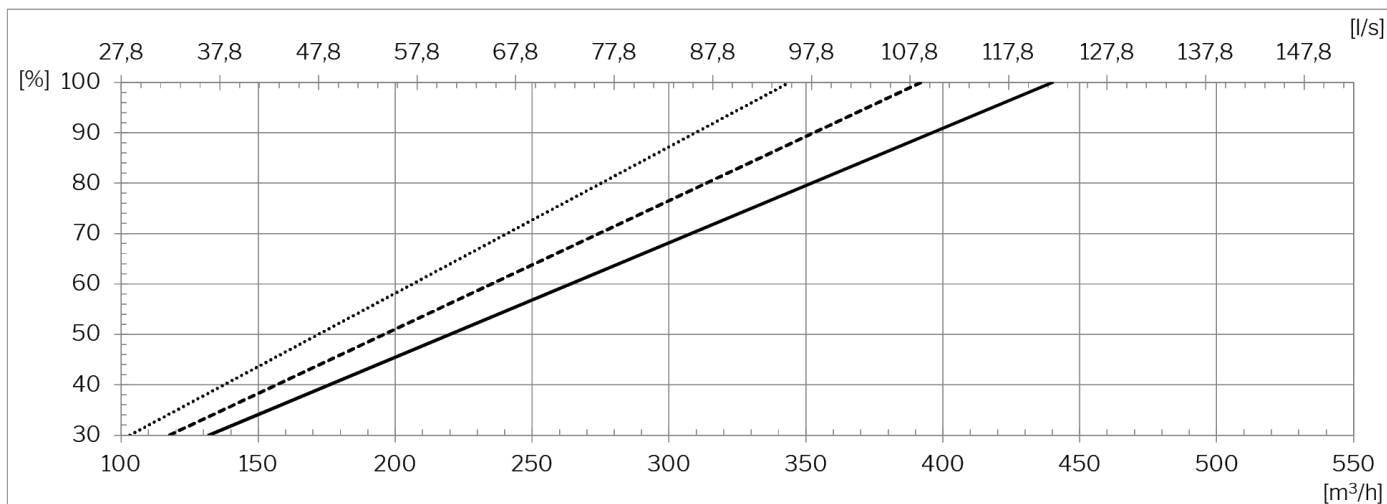

- 30 dB(A)
- 33 dB(A)
- 35 dB(A)

Sound pressure $L_{pA, eq}^{A,D}$

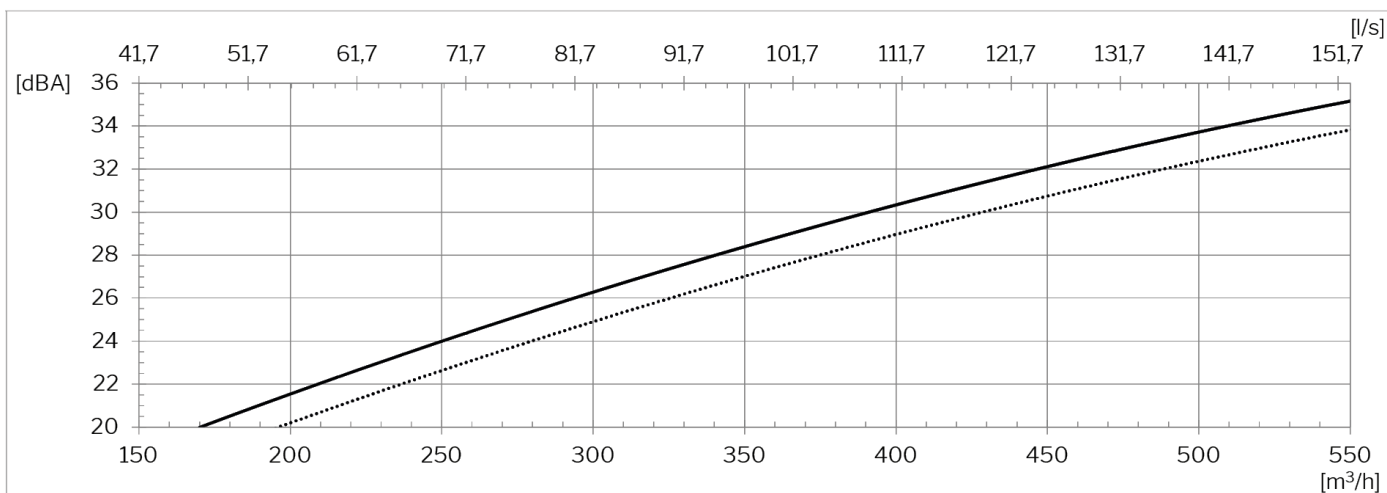

- Reverberation time T = 0.6 s
- Reverberation time T = 0.9 s

^D Sound pressure level $L_{pA, eq}$ is measured at a height of 1.2 m with at horizontal distance of 1 m from the unit in a room with a size of 200 m³ and a reverberation time of T = 0.6 s, corresponding to a room attenuation of 7.5 dB.

Temperature efficiency acc. to EN 308

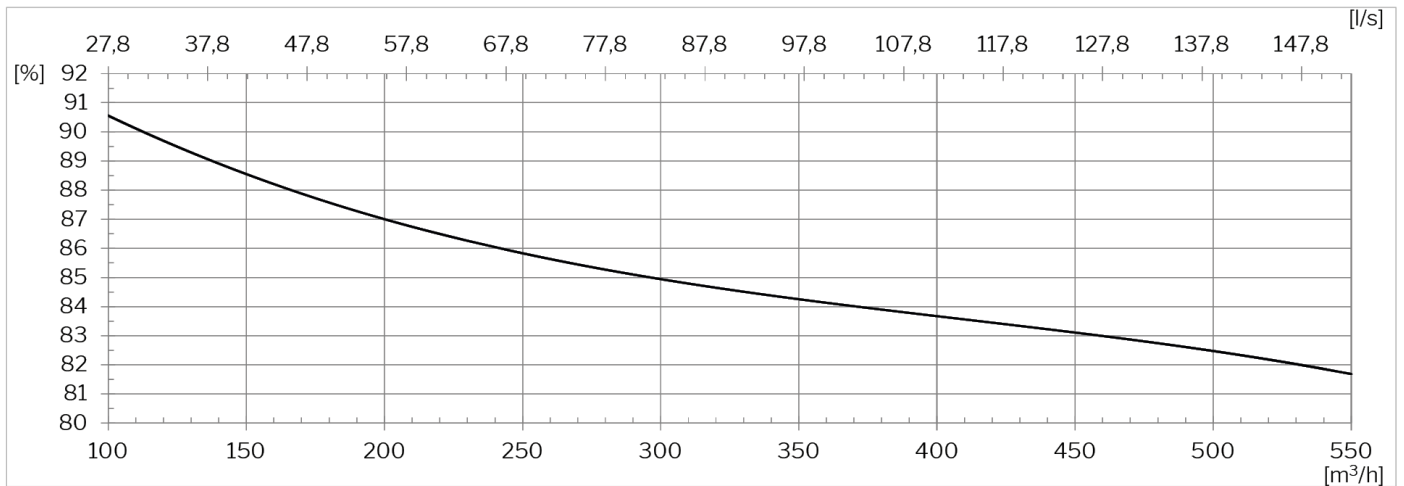

—— Balanced airflow: Extraction: 25 °C, 28 % RH; Intake: 5 °C.

Power consumption^A

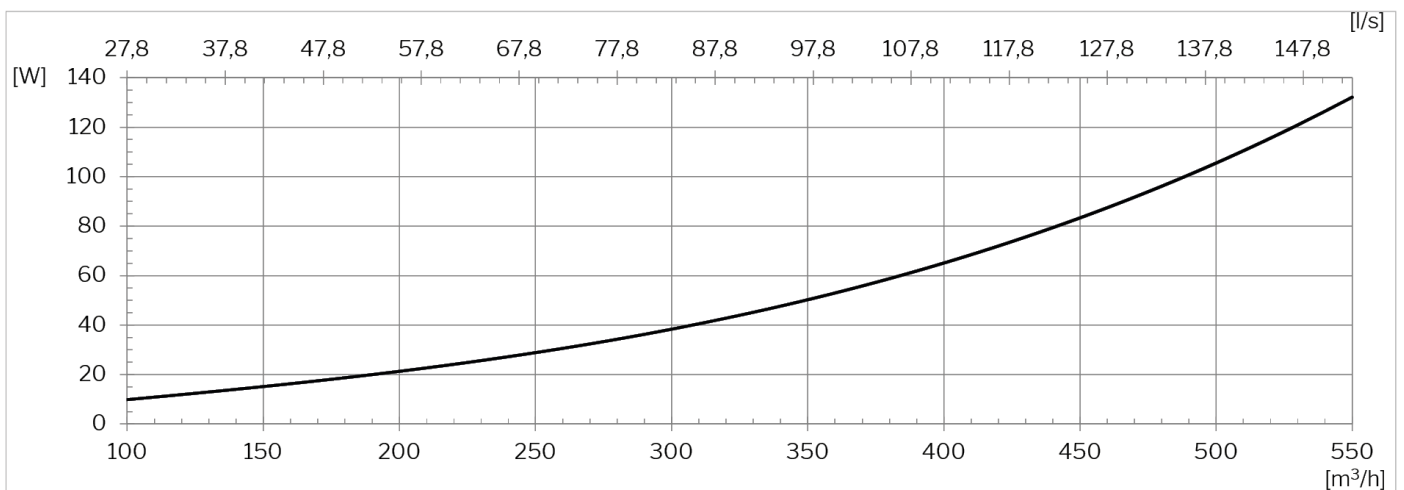

—— Intake filter ePM₁₀ 50% + extract filter ePM₁₀ 50%

SFP^E

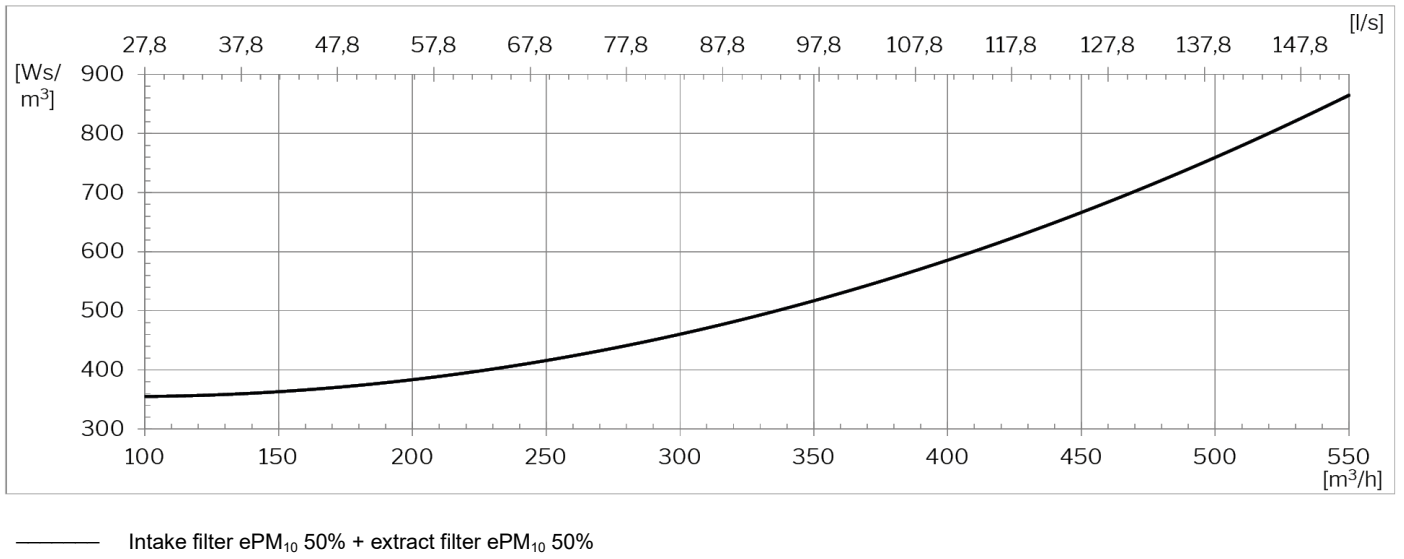

External pressure loss^A

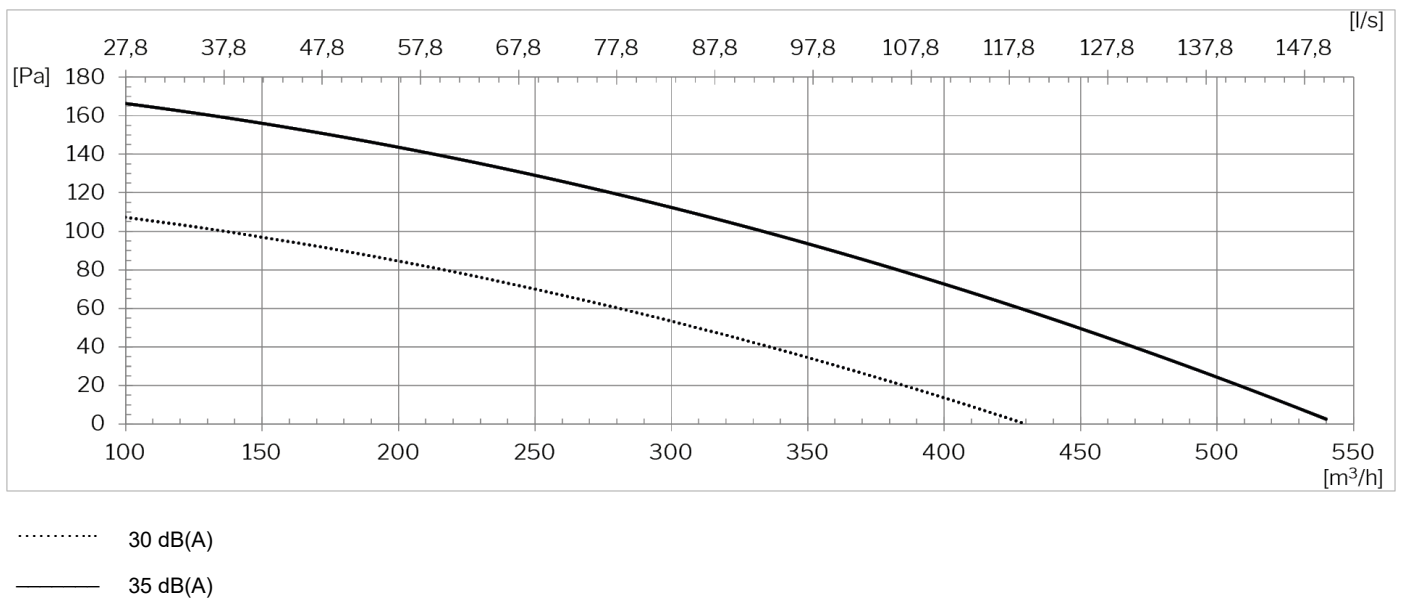

^E The SFP calculation includes power consumption for operating fans but not controls, display panels, etc.

Throw (0.2 m/s)

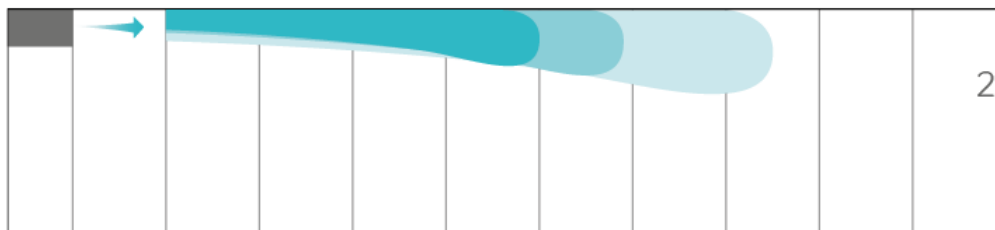
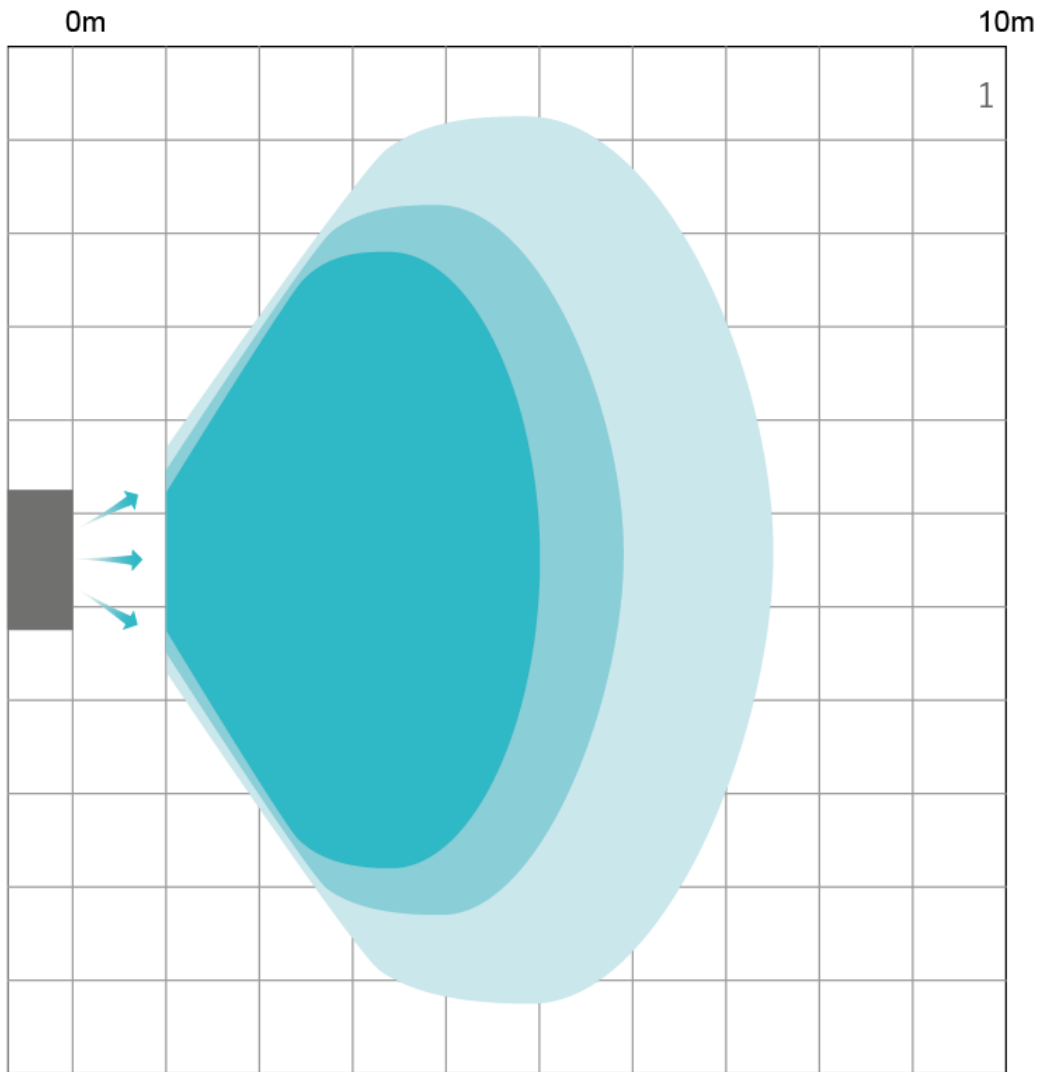



- 350 m³/h
- 450 m³/h
- 550 m³/h

- 1 Throw seen from above
- 2 Throw seen from the side

Version overview

Exhaust and intake

- H:** Horizontal
- V:** Vertical
- HRE:** Horizontal REctangular
-  Exhaust
-  Intake

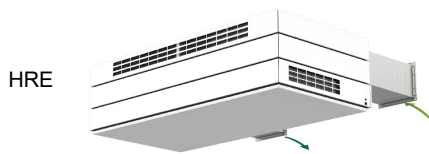
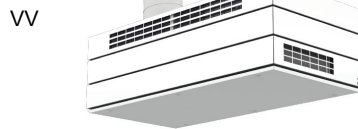
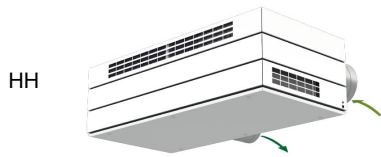

Inlet and extract

- T:** Top
- C:** Center
- B:** Bottom
- DI:** Ducted Inlet
- DE:** Ducted Extract
-  Inlet
-  Extract

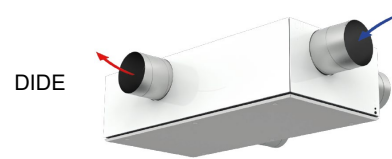
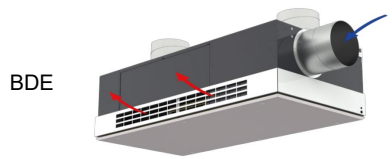
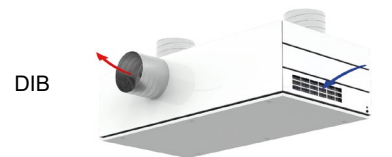
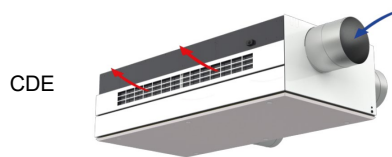
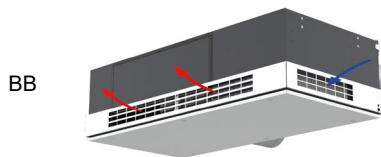
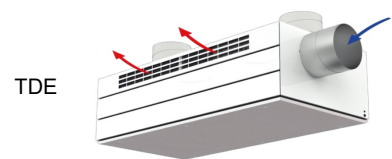
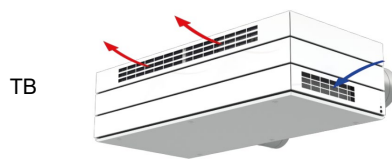
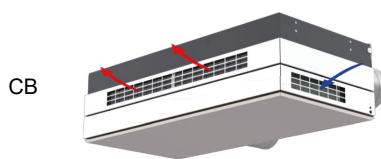

Standard and options

Counterflow heat exchanger (Aluminium)	✓
Enthalpy counterflow heat exchanger (Polymer membrane)	si
Combination counterflow heat exchanger (Polymer membrane)	si
Motor-driven bypass	✓
Motor-driven intake air damper	✓
Motor-driven exhaust air damper	✓
Capacitive return for motorized exhaust and intake air dampers	opt.
Electric preheating surface	opt.
Electric comfort heating surface	opt.
Water heating surface	opt.
Condensate pump	opt.
PIR/Motion sensor, wall-mounted	opt.
PIR/Motion sensor, integrated	opt.
CO ₂ sensor, wall-mounted	opt.
CO ₂ sensor, integrated	opt.
TVOC sensor, integrated	opt.
CO ₂ & TVOC sensor, integrated	opt.
Hygrostat, wall-mounted	si
Service switch	si

Energy Meter	opt.
Cooling module, CC (only for horizontal model)	opt.
Intake filter ePM ₁₀ 50%	opt.
Intake filter ePM ₁ 55%	opt.
Intake filter ePM ₁ 80%	si
Extract filter ePM ₁₀ 50%	✓
Wall-/ceiling bracket	opt.
Ceiling frame	opt.
Airlinq® Viva control panel	opt.
Airlinq® Orbit control panel	opt.
Airmaster Airlinq® Online	opt.
Airlinq® Online API	opt.
Airlinq® BMS	opt.
LON® module	si
KNX® module	si
MODBUS® RTU RS485 module	opt.
BACnet™ MS/TP module	opt.
BACnet™ IP module	opt.
Mini B USB (on front of unit)	si

✓: standard opt.: optional si: special item

Schematic sketch

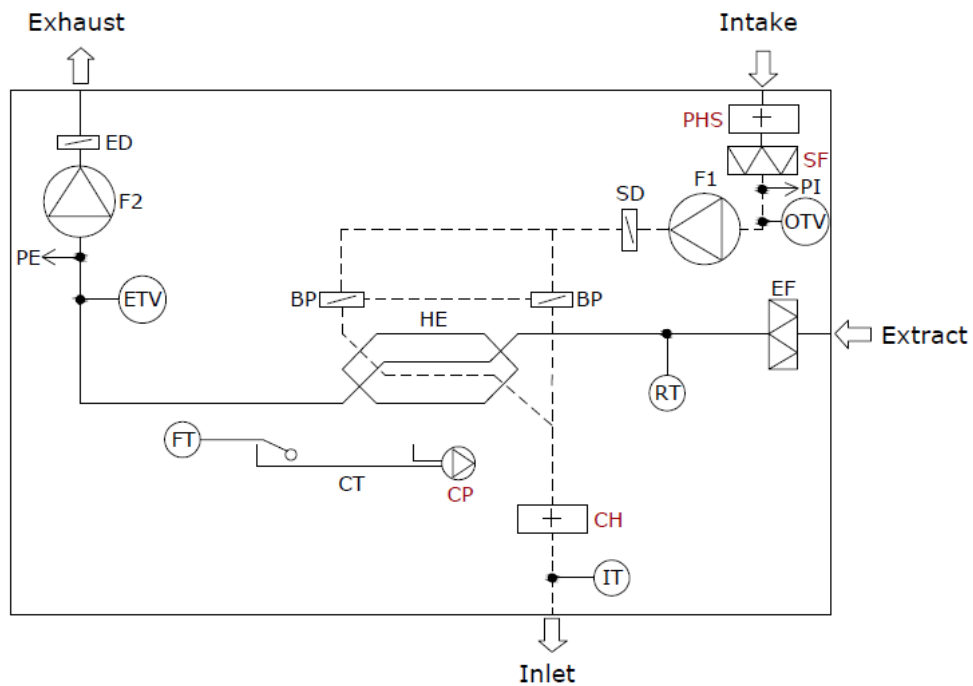

BP	Bypass damper (motor-driven)	HE	Counterflow heat exchanger
CH	Electric comfort heating surface (option)	IT	Inlet air temperature sensor
CP	Condensate pump (option)	OTV	Intake air temperature sensor
CT	Condensate tray	PE	Flow meter, extracted air
ED	Exhaust air damper (motor-driven)	PHS	Preheating surface (option)
EF	Extract air filter	PI	Flow meter, intake air
ETV	Exhaust temperature sensor	RT	Room temperature sensor
FT	Float	SD	Intake air damper (motor-driven)
F1	Intake air fan	SF	Intake air filter (option)
F2	Extract air fan		